

Frequency Inverter Selection Guide

Automated production and life



Service hotline: 027-87002560
Official website: www.sineedrive.com

Shenzhen Sine Electric Co., Ltd.

Address: Floor 5, Workshop No.7, Antuoshan Hi-Tech Industrial Park,
Sha'er Community, Shajing Sub-district, Bao'an District, Shenzhen

Wuhan Sine Electric Technology Co., Ltd

Address: 82 Gaoxin Fifth Road, East Lake High-Tech Development Zone, Wuhan

Wuxi Branch of Shenzhen Sine Electric Co., Ltd.

Address: 6/F, Building No. 56, Huaqing Creativity Park, 33 Zhihui Road,
Huishan Economic Zone, Wuxi City



High Performance



Stable&Reliable



Adaptable



Scalable

CONTENTS

02 EM760 series inverter

12 EM730 series inverter

21 EM700 series economical frequency inverter

28 BR100 Braking Unit



SINEE

Since its establishment in 2003, SINEE (Shenzhen Sine Electric Co., Ltd.) has been focusing on the R&D, production and sales of motor drive and control systems in the field of industrial automation. With the mission of “automated production and life”, it provides the most valuable products and services for users. In 2021, SINEE was listed on the Science and Technology Innovation Board of the Shanghai Stock Exchange (stock code: 688395). At present, it has R&D, production and service bases in Shenzhen, Wuhan and Wuxi.

Reliable drives & Solutions by technology

SINEE has established key core technology platforms such as high-performance variable frequency vector control technology, high-precision servo drive technology, embedded computer control technology, and power electronic application technology. It mainly provides inverters, integrated units, servo system products and system solutions.



Vision
Automated production and life



Business Department
Motor drive and control system solution provider



Client
Mechanical equipment manufacturer, electronic control system integrator and distributor



Competitiveness
Industry market solution and customization

EM760 Series Inverter

Three-phase AC 340V-460V 0.75kW-710kW
660V-690V 18.5kW-800kW

The EM760 series inverter is a high-performance vector control inverter launched by SINEE, which integrates the synchronous motor drive and asynchronous motor drive. It supports three-phase AC asynchronous motors and permanent magnet synchronous motors; drive control technologies, such as the improved vector VF control technology (VVF), speed sensorless vector control technology (SVC) and speed sensor vector control technology (FVC); speed output and torque output; Wi-Fi access and background software debugging; expansions such as I/O expansion cards, communication bus expansion cards and PG cards.

Features of the EM760 series inverter:

1. Standard built-in C3 filter to meet the high requirements of electromagnetic compatibility
2. Built-in DC reactor to reduce input current distortion and increase the power factor
3. Standard LCD panel, easy to operate
4. Integration of the permanent magnet synchronous motor / asynchronous motor / permanent magnet synchronous reluctance motor / high-speed motor drive
5. Mainstream bus expansion cards: PROFINET, CANopen, EtherCAT
6. PG cards: OC, differential, UVW, resolver PG card, sine and cosine PG card





Model and Product List

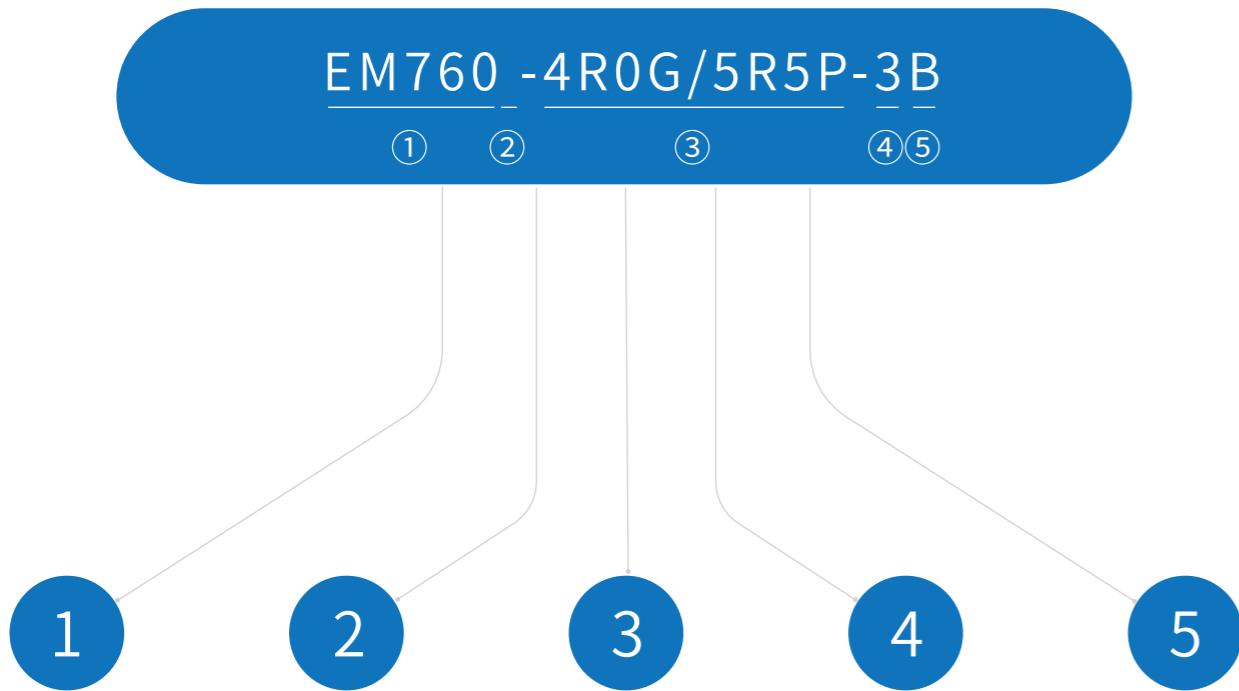

em760:
High-performance series

Null:
Installation in cabinet
C: Cabinet type

Identification	Compatible motor type
G	Universal model
P	Fan pump type

Voltage level
2: Three-phase 220V
3: Three-phase 380V
6: Three-phase 660V

B: Built-in braking unit
None: Without braking unit

COMPATIBLE LOAD POWER

OR7	4R0	...	018	...
0.75kW	4.0kW	...	18.5kW	...

Product List

RATED VOLTAGE OF POWER SUPPLY:
THREE-PHASE AC 340V TO 460V

Model	Applicable motor power (kW)	Rated output current (A)
EM760-0R7G/1R5P-3B	0.75/1.5	2.5/4.2
EM760-1R5G/2R2P-3B	1.5/2.2	4.2/5.6
EM760-2R2G/3R0P-3B	2.2/3.0	5.6/7.2
EM760-4R0G/5R5P-3B	4.0/5.5	9.4/12
EM760-5R5G/7R5P-3B	5.5/7.5	13/17
EM760-7R5G/9R0P-3B	7.5/9.0	17/20
EM760-011G/015P-3B	11/15	25/32
EM760-015G/018P-3B	15/18.5	32/38
EM760-018G/022P-3B	18.5/22	38/44
EM760-022G/030P-3B	22/30	45/59
EM760-030G/037P-3/3B	30/37	60/73
EM760-037G/045P-3/3B	37/45	75/87
EM760-045G/055P-3/3B	45/55	90/106
EM760-055G/075P-3/3B	55/75	110/145
EM760-075G/090P-3/3B	75/90	150/169
EM760-090G/110P-3	90/110	176/208
EM760-110G/132P-3	110/132	210/248
EM760-132G/160P-3	132/160	253/298
EM760-160G/185P-3	160/185	304/350
EM760-200G/220P-3	200/220	380/410
EM760-220G/250P-3	220/250	426/456
EM760-250G/280P-3	250/280	465/510
EM760-280G/315P-3	280/315	520/573
EM760-315G/355P-3	315/355	585/640
EM760-355G/400P-3	355/400	650/715
EM760-400G/450P-3	400/450	725/810
EM760C-450G/500P-3	450/500	820/900
EM760C-500G/560P-3	500/560	900/1010
EM760C-560G/630P-3	560/630	1010/1140



Technical Specification



POWER SUPPLY

Item	Specification
Rated voltage of power supply	Three-phase 340V-10% to 460V+10% 50-60Hz \pm 5%; voltage unbalance rate: <3%

OUTPUT

Item	Specification
Maximum output voltage	The maximum output voltage is the same as the input power voltage.
Rated output current	Continuous output of 100% rated current
Maximum overload current	G model: 150% rated current for 60s P model: 120% rated current for 60s (2kHz carrier; please derate for carriers above this level)

CONTROL FUNCTION

Item	Specification
Driving mode	V/F control (VF) Speed sensorless vector control (SVC) Speed sensor vector control (FVC)
Input mode	Frequency (speed) input, torque input
Start and stop control mode	Keyboard, control terminal (two-line control and three-line control), communication
Frequency control range	0.00 ~ 600.00Hz/0.0 ~ 3000.0Hz
Input frequency resolution	Digital input: 0.01Hz Analog input: 0.1% of maximum frequency
Speed control range	1:50 (VVF) 、 1:200 (SVC) 、 1:1000 (FVC)
Speed control accuracy	\pm 0.5%(VVF)、 \pm 0.2%(SVC)、 \pm 0.02%(FVC)
Acceleration and deceleration time	0.01 s to 600.00 s / 0.1 s to 6,000.0 s / 1 s to 60,000 s
Voltage/frequency characteristics	Rated output voltage: 20% to 100%, adjustable; fundamental frequency: 1Hz to 600Hz/3000Hz, adjustable
Torque boost	Fixed torque boost curve, any V/F curve optional
Starting torque	150%/3Hz (VVF) 、 150%/0.25Hz (SVC) 、 180%/0Hz (FVC)
Torque control accuracy	\pm 5% rated torque (SVC), \pm 3% rated torque (FVC)
Self-adjustment of output voltage	When the input voltage changes, the output voltage will basically remain unchanged.
Automatic current limit	Output current is automatically limited to avoid frequent overcurrent trips.
DC braking	Braking frequency: 0.01 to maximum frequency Braking time: 0~30S Braking current: 0% to 100% of rated current
Signal input source	Communication, multi-speed, analog, high-speed pulse, etc.

INPUT/OUTPUT

Item	Specification
Reference power supply	10.5V \pm 0.5V/20mA
Terminal control power	24V/200mA
Digital input terminal	7 (standard X1 to X7) + 3 (extension card X8 to X10) digital multi-function inputs: X7 can be used as a high-speed pulse input terminal (F02.06 = 35/38/40); The remaining 9 channels (X1 to X6 and X8 to X10) can only be used as ordinary digital input terminals.
Analog input terminal	3 (standard AI1 to AI3) + 1 (extension card AI4) analog inputs: One AI1: support 0 to 10V or -10 to 10V, optional through function code F02.62; Two AI2/AI3: support 0 to 10V or 0 to 20mA or 4 to 20mA, through the function code F02.63, F02.64 is optional; One AI4: support 0 to 10V or -10 to 10V, optional through function code F02.65
Digital output terminal	2 (standard Y1/Y2) open-collector multi-function outputs + 2 (R1:EA/EB/EC and R2:RA/RB/RC) relay multi-function outputs + 2 (extension card) (R3: RA3/RC3 and R4: RA4/RC4) relay multi-function outputs Maximum output current of the collector: 50 mA; Relay contact capacity 250VAC/3A or 30VDC/1A, with EA-EC and RA-RC normally open, EB-EC and RB-RC normally closed; RA3-RC3, RA4-RC4 normally open
Analog output terminal	Two (M1/M2) multi-function analog output terminals, with output of 0 to 10V or 0 to 20mA or 4 to 20mA, optional through function codes F03.34 and F03.35

OPERATION PANEL

Item	Specification
LCD display	The LCD displays relevant information about the inverter.
Parameter copying	Parameter settings of the inverter can be uploaded and downloaded for fast parameter copying.

PROTECTION

Item	Specification
Protective Function	Short circuit, overcurrent, overvoltage, undervoltage, phase loss, overload, overheat, overspeed, load loss, external fault, etc.

USE CONDITIONS

Item	Specification
Location	Indoor, at an altitude of less than 1 km, free of dust, corrosive gases and direct sunlight
Applicable environment	-10°C to +50°C, derating by 5% per 1°C increase above 40°C, 20% to 90%RH (non-condensing)
Vibration	Less than 0.5g
Storage environment	-40°C~ +70°C
Installation method	Wall-mounted, floor-standing electrical control cabinet, through-wall

PROTECTION LEVEL

Item	Specification
Protection level	Standard IP21/IP20 (remove the plastic cover at the top of the plastic case)

COOLING METHOD

Item	Specification
Cooling method	Forced air cooling

Dimension

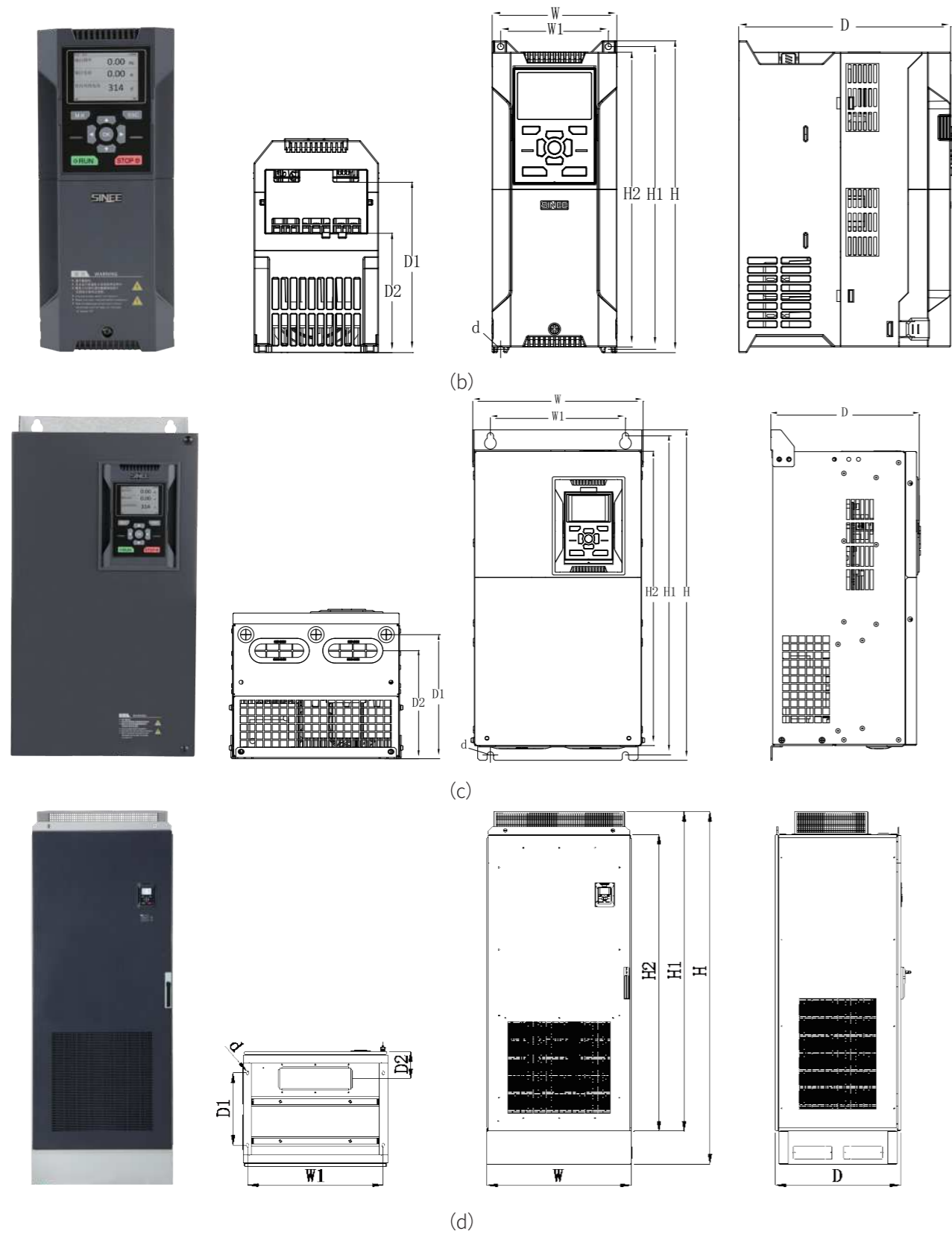

Specifications	W(mm)	W1(mm)	H(mm)	H1(mm)	H2(mm)	D(mm)	D1(mm)	D2 (mm)	d(mm)	appearance	
EM760-0R7G/1R5P-3B	95	82	230	222	218	171	132	96	4.5	(b)	
EM760-1R5G/2R2P-3B											
EM760-2R2G/3R0P-3B											
EM760-4R0G/5R5P-3B											
EM760-5R5G/7R5P-3B	110	95	275	267	260	187	146	105	5.5		
EM760-7R5G/9R0P-3B											
EM760-011G/015P-3B	140	124	297	289	280	207	163	120	5.5		
EM760-015G/018P-3B											
EM760-018G/022P-3B	190	171	350	340	330	220	173	128	7		
EM760-022G/030P-3B											
EM760-030G/037P-3/3B	254	200	484	465	440	221	180.5	158	9.5		(c)
EM760-037G/045P-3/3B											
EM760-045G/055P-3/3B	304	210	540	519	480	263	217	197	9.5		
EM760-055G/075P-3/3B											
EM760-075G/090P-3/3B	324	230	638	613	570	264	220	181	11.5		
EM760-090G/110P-3	339	270	623	600	578	296	243	243	11.5		
EM760-110G/132P-3											
EM760-132G/160P-3	422	320	786	758	709	335	271	256.4	11.5		
EM760-160G/185P-3											
EM760-200G/220P-3	441	320	1025	989	942	357	/	285	11.5		
EM760-220G/250P-3	560	450	1204	1170.5	1100	400	/	333	13		
EM760-250G/280P-3											
EM760-280G/315P-3	660	443	1597	1567	1504	430	375.5	323.5	13		
EM760-315G/355P-3											
EM760-355G/400P-3	805	756	2145	1945	1804	700	440	165	13	(d)	
EM760-400G/450P-3											
EM760C-450G/500P-3											
EM760C-500G/560P-3											
EM760C-560G/630P-3											

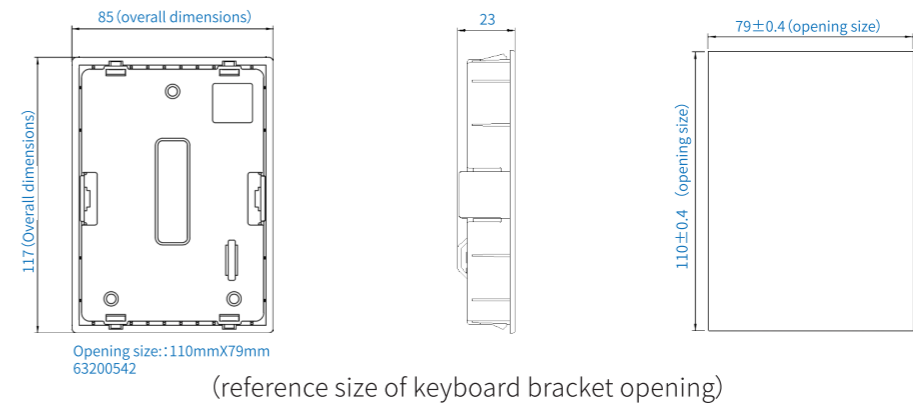

Standard Wiring Diagram of Control Circuit

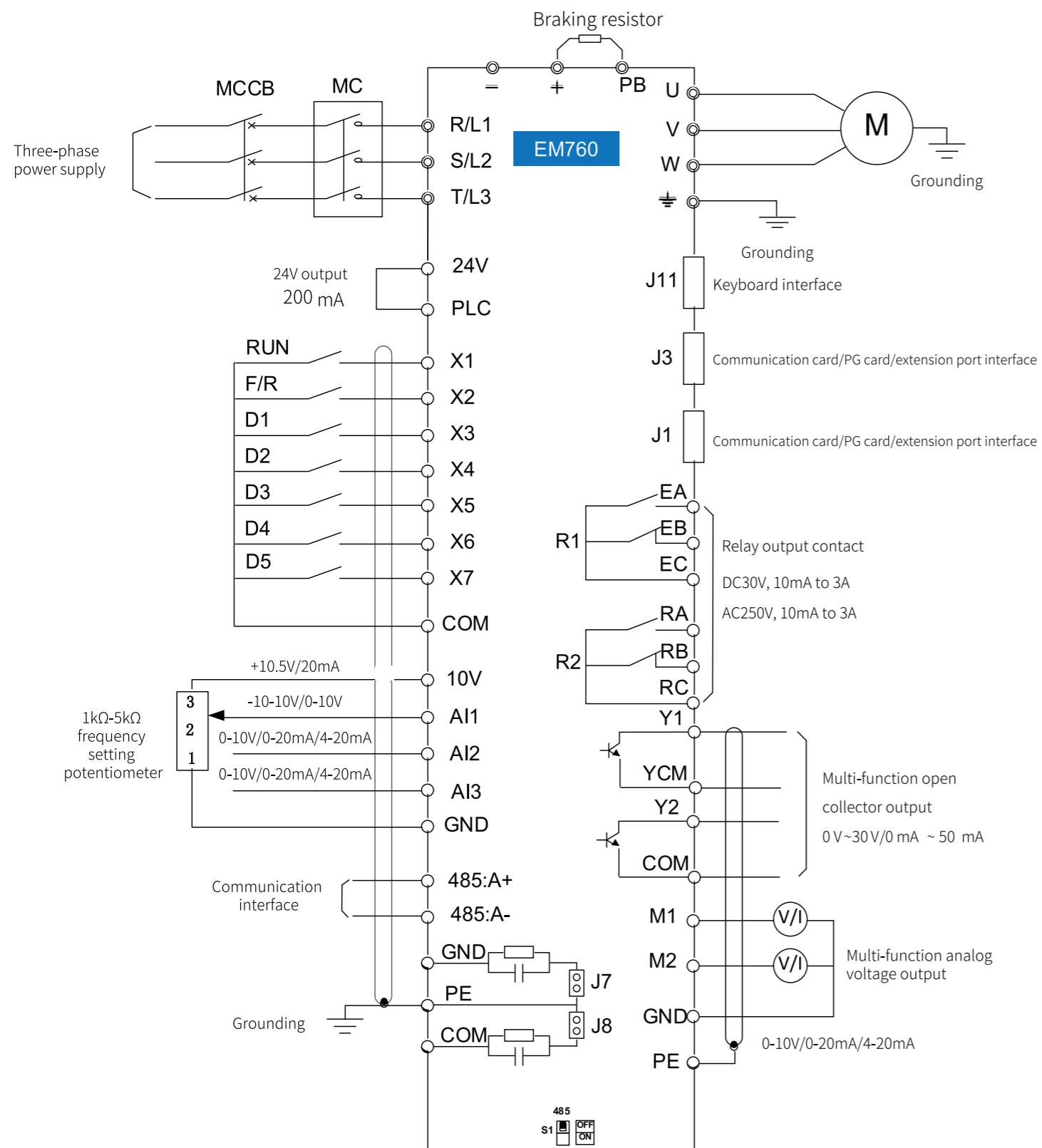

Options of EM760 series inverter

Select accessories	Name & Model	Function	Photo
Communication card	EM760-CM-C1	This communication card is required for CANopen bus communication. Connect the inverter to CANopen bus for bus communication.	
	EM760-CM-PN1	profinet fieldbus adapter card, in line with the international profinet Ethernet standard.	
IO expansion card	EM760-IO-A1	The IO expansion card is used for expansion to 3 multi-function digital inputs, 2 relay outputs and 4 analog inputs, supporting PT100/PT1000/PTC/KTY84 and other common motor temperature sensors, respectively.	
PG card	EM760-PG-OD1	It can be used with differential (line drive) output encoder, open collector output encoder and push-pull complementary output encoder. The optional output voltage is 5V and 12V (5V by default).	
	EM760-PG-OD2	It can be used with differential (line drive) output encoder, open collector output encoder, push-pull complementary output encoder, and has the function of frequency dividing output. Its output is the NPN open collector output. The optional output voltage is 5V and 12V (5V by default).	
	EM760-PG-R1	Rotary transformer PG card	
	EM760-PG-U1	UVW differential input PG card	
	EM760-PG-S1	Sincos encoder PG card	
Others	LED two-row keyboard	Support double-line display of two inverter status parameters at the same time. One parameter can be changed by operating the left and right key. Users can perform parameter setting, status monitoring, start/stop and fault query.	
	WIFI module		
	Energy consumption braking unit BR100-045 BR100-160 BR100-200 BR100-315 BR100-400 BR100-220-6	It has the functions of stable and reliable working performance and protection against over-temperature and braking resistor short circuit, and can be used for inverter-driven lifting equipment, centrifuges, washing machines, spin dryers, and rapid parking.	

EM730 Series Inverter

Single-phase/three-phase 220V-240V 0.4kW-2.2kW
Three-phase AC 340V-460V 0.75kW-450kW

The EM730 series inverter is a high-reliability general-purpose inverter launched by SINEE. EM730 supports three-phase AC asynchronous motors and permanent magnet synchronous motors. They support a variety of drive control technologies, such as the vector VF (VVF) control and speed sensorless vector control (SVC); speed output and torque output; and Wi-Fi access and background software debugging.

Features of the EM730 series inverter:

- 1.Support the mobile APP and Wi-Fi module to facilitate inverter debugging and monitoring
- 2.Reliable operation with full load at 50°C ambient temperature
- 3.Integration of special functions for rewinding and unwinding
- 4.Support the high-frequency output up to 3000Hz for driving high-speed motors
- 5.Support the 100kHz high-speed pulse input
- 6.he metal substrate should adapt to the vibratory environment to reduce the induced voltage of the motor.
- 7.he built-in filter is close to Level C3, so the external interference is greatly reduced.



Model and Product List

PRODUCT LIST

RATED VOLTAGE OF POWER SUPPLY:
THREE-PHASE 340~460V

Model	Applicable motor power (kW)	Heavy-duty rated output current (A)	Light-duty rated output current (A)
EM730-0R7-3B	0.75	2.5	3
EM730-1R5-3B	1.5	4.2	4.6
EM730-2R2-3B	2.2	5.6	6.5
EM730-4R0-3B	4.0	9.4	10.5
EM730-5R5-3B	5.5	13	15.7
EM730-7R5-3B	7.5	17	20.5
EM730-011-3B	11	25	28
EM730-015-3B	15	32	36
EM730-018-3B	18.5	38	41.5
EM730-022-3B	22	45	49
EM730-030-3/3B	30	60	70
EM730-037-3/3B	37	75	85
EM730-045-3	45	90	105
EM730-055-3	55	110	134
EM730-075-3	75	150	168
EM730-090-3	90	176	200
EM730-110-3	110	210	235
EM730-132-3	132	253	290
EM730-160-3	160	304	340
EM730-185-3	185	340	—
EM730-200-3	200	380	—
EM730-220-3	220	426	—
EM730-250-3	250	465	—
EM730-280-3	280	520	—
EM730-315-3	315	585	—
EM730-355-3	355	650	—
EM730-400-3	400	725	—
EM730-450-3	450	820	—

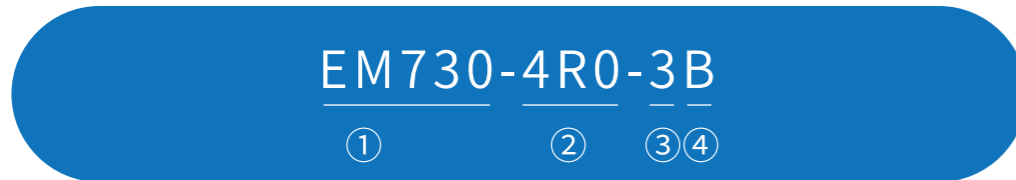

EM730: EM730 INVERTER Power (kW) of the supporting motor of inverter B: BUILT-IN BRAKING UNIT Input power voltage level:
 For example: 4R0: 4.0kW 037: 37kW
 2: Single/three-phase 220V
 3: Three-phase 380V

PRODUCT LIST

RATED VOLTAGE OF POWER SUPPLY:
SINGLE-PHASE/THREE-PHASE AC 200V-240V

Model	Applicable motor power (kW)	Heavy-duty rated output current (A)	Light-duty rated output current (A)
EM730-0R4-2B	0.4	2.8	3.2
EM730-0R7-2B	0.75	4.8	5.0
EM730-1R5-2B	1.5	8	8.5
EM730-2R2-2B	2.2	10	11.5



Technical Specification



POWER SUPPLY

Item	Specification
Rated voltage of power supply	Three-phase 340V-10% to 460V+10%, Single-phase/three-phase 200V-10% to 240V+10%; 50-60Hz ± 5%; voltage unbalance rate: <3%



OUTPUT

Item	Specification
Maximum output voltage	The maximum output voltage is the same as the input power voltage.
Rated output current	Continuous output of 100% rated current
Maximum overload current	150% of heavy-duty rated current for 60s (185kW-450kW: 140% of heavy-duty rated current for 60s) 120% of light-duty rated current for 60s



CONTROL

Item	Specification
Driving mode	V/F control (VVF); speed sensorless vector control (SVC)
Input mode	Frequency (speed) input, torque input
Start and stop control mode	Keyboard, control terminal (two-line control and three-line control), communication
Frequency control range	0.00 ~ 600.00Hz/0.0 ~ 3000.0HZ
Input frequency resolution	Digital input: 0.01Hz/0.1Hz Analog input: 0.1% of maximum frequency
Speed control range	1:50 (VVF) 、 1:200 (SVC)
Speed control accuracy	Rated synchronous speed ± 0.2%
Acceleration and deceleration time	0.01 s to 600.00 s / 0.1 s to 6,000.0 s / 1 s to 60,000 s
Voltage/frequency characteristics	Rated output voltage: 20% to 100%, adjustable Fundamental frequency 1Hz to 600Hz/3000Hz, adjustable
Torque boost	Fixed torque boost curve Any V/F curve is acceptable.
Starting torque	150%/1Hz (VVF) 150%/0.25Hz (SVC)
Precision torque control	±5% rated torque (SVC)
Self-adjustment of output voltage	When the input voltage changes, the output voltage will basically remain unchanged.
Automatic current limitation	Output current is automatically limited to avoid frequent overcurrent trips.
DC braking	Braking frequency: 0.01 to maximum frequency Braking time: 0~30S Braking current: 0% to 100% of rated current
Signal input source	Communication, multi-speed, analog, etc.



INPUT/OUTPUT

Item	Specification
Reference power supply	10V/20mA
Terminal control power	24V/100mA
Digital input terminal	5-channel digital multi-function input: X1 to X5 X5 can be used as the high-speed pulse input (max. 100kHz).
Analog input terminal	2-channel analog inputs: One (AI1) voltage source: -10 to 10V input; One channel (AI2): 0 to 10V input voltage or 0 to 20mA input current optional;
Digital output terminal	Multi-function output of one open collector and one relay Maximum output current of the collector: 50mA; Relay contact capacity: 250VAC/3A or 30VDC/1A, EA-EC: normally open; EB-EC: normally closed
Analog output terminal	One multi-function analog terminal output M1: 0-10V/0-20mA multi-function analog output terminal



OPERATION PANEL

Item	Specification
LED display	The LED digital tube displays relevant information about the inverter.



PROTECTION

Item	Specification
Protective Function	Short circuit, overcurrent, overvoltage, undervoltage, phase loss, overload, overheat, load loss, external fault, etc.



USE CONDITIONS

Item	Specification
Location	Indoor, at an altitude of less than 1 km, free of dust, corrosive gases and direct sunlight. When the altitude is higher than 1km, it is derated by 1% per 100m. The maximum allowable altitude is 3km.
Applicable environment	-10°C to +60°C, 5% to 95% RH (non-condensing). When the ambient temperature exceeds 50°C, it needs to be derated by 3% per 1°C temperature rise. The maximum allowable ambient temperature is 60°C.
Vibration	Less than 0.5g
Storage environment	-40°C~ +70°C
Installation method	Wall-mounted or installed in the cabinet



PROTECTION LEVEL

Item	Specification
Protection level	Standard IP20/IP21 (with plastic baffle)



COOLING METHOD

Item	Specification
Cooling method	Forced air cooling

Dimension

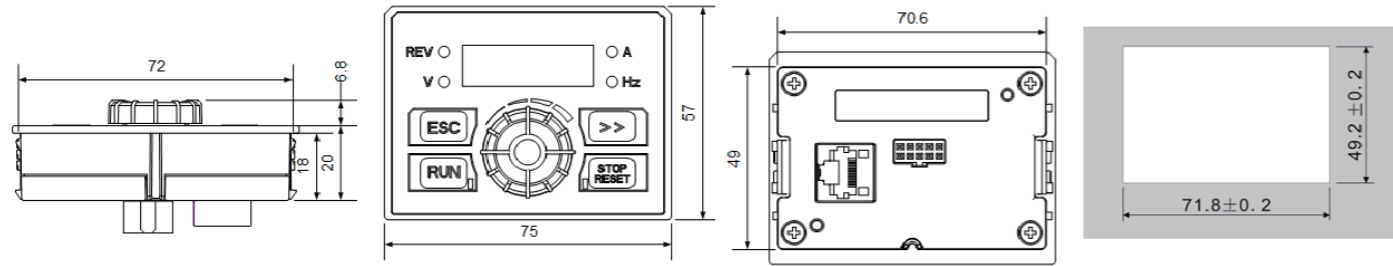

Outline Dimensions of EM730 Series Inverter and Keyboard

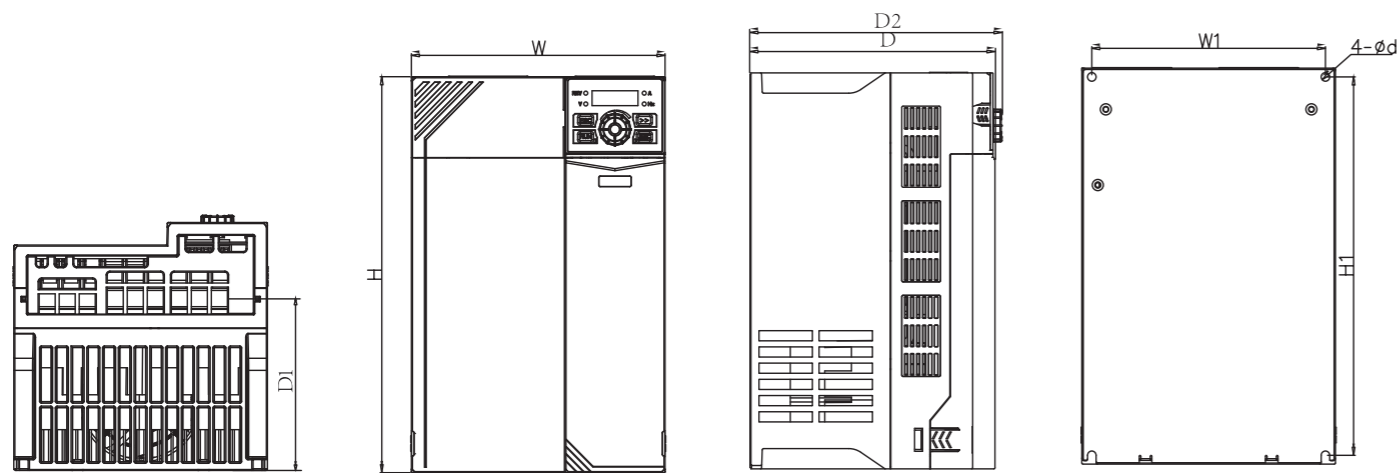

(a) Appearance of EM730-0R7-3B to EM730-022-3B inverters

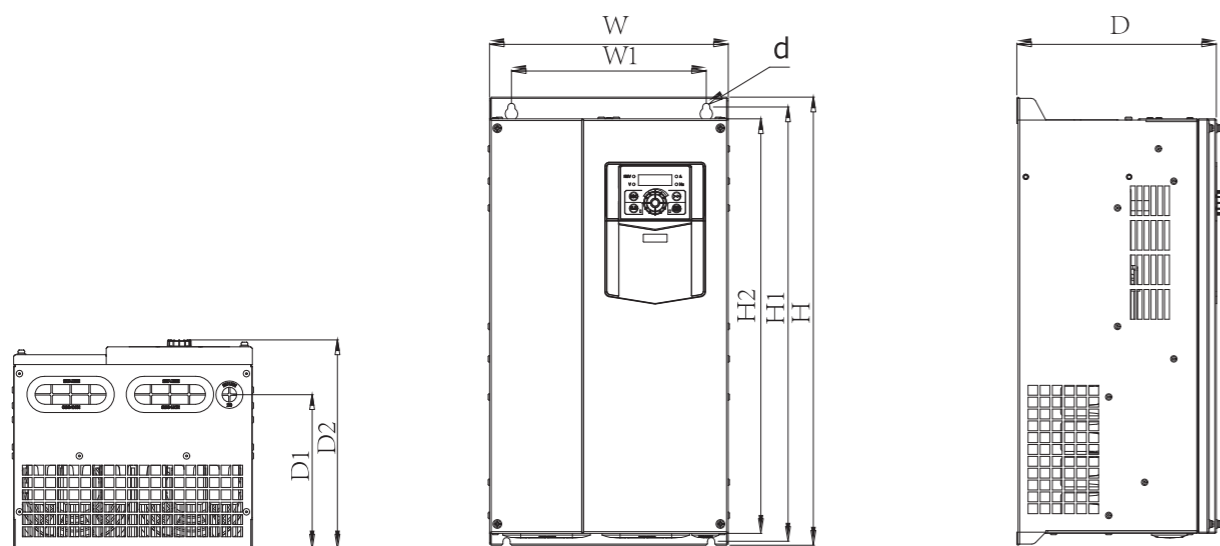

(b) Appearance of EM730-030-3B to EM730-450-3 inverters

Specifications	W(mm)	W1(mm)	H(mm)	H1(mm)	H2(mm)	D(mm)	D1(mm)	D2(mm)	d(mm)
EM730-0R4-2B	75	65	142	132		146	67	152	4.5
EM730-0R7-2B									
EM730-1R5-2B	93	82	172	163		136	85	141	4.7
EM730-2R2-2B									
EM730-0R7-3B	75	65	142	132		146	67	152	4.5
EM730-1R5-3B									
EM730-2R2-3B	93	82	172	163		136	85	141	4.7
EM730-4R0-3B									
EM730-5R5-3B	109	98	207	196		154	103	160	5.5
EM730-7R5-3B									
EM730-011-3B	136	125	250	240		169	115	174	5.5
EM730-015-3B									
EM730-018-3B	190	175	293	280		184	145	189	6.5
EM730-022-3B									
EM730-030-3	245	200	454	440	420	205	156	212	7.5
EM730-030-3B									
EM730-037-3									
EM730-037-3B									
EM730-045-3	300	266	524	508	480	229	174	236	9
EM730-055-3									
EM730-075-3	335	286	580	563	536	228	177	235	9
EM730-090-3									
EM730-110-3	335	286	630	608	570	310	247	317	11
EM730-132-3									
EM730-160-3	430	330	770	747	710	311	248	319	13
EM730-185-3									
EM730-200-3	441	320	1025	989	942	357		285	11.5
EM730-220-3									
EM730-250-3									
EM730-280-3	560	450	1024	1170.5	1100	400		333	13
EM730-315-3									
EM730-355-3	660	443	1597	1567	1504	430	375.5	325.5	13
EM730-400-3									
EM730-450-3									

Standard Wiring Diagram of Control Circuit

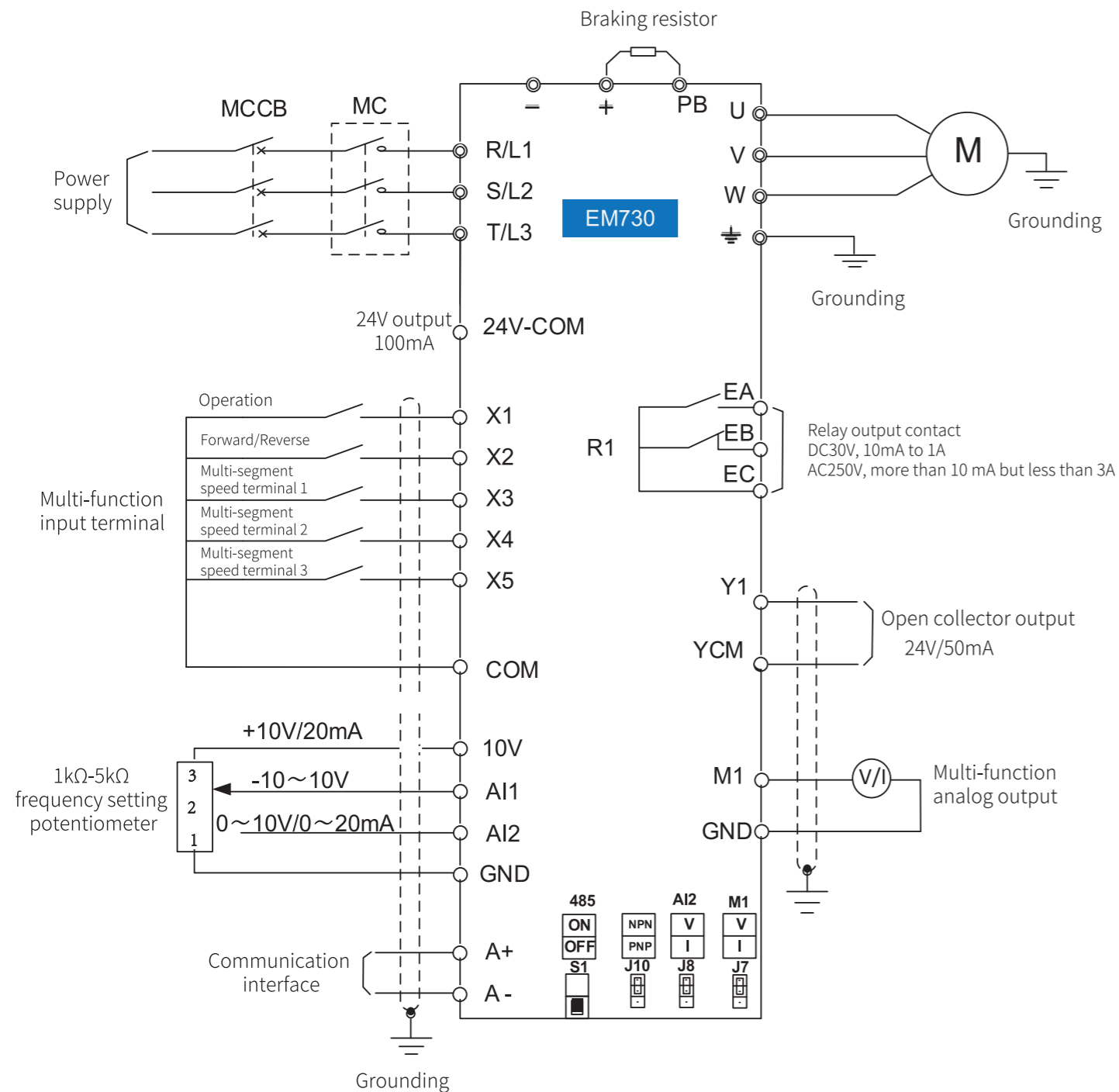

- It is recommended to use the wires with a diameter of 0.5-1mm² in the control circuit.
- Install the control circuit terminals with the PH0 Phillips screwdriver. The tightening torque should be 0.5N.m.

EM700 Series Economical Frequency Inverter

Single/three-phase 200V-240V 0.4-2.2kW
 Three-phase 340-460V 0.75-5.5kW

EM700 series frequency inverter have the following features:

1. Compact size, supports side-by-side installation;
2. Pluggable main power terminals for quick installation and maintenance
3. 50°C ambient temperature, no need to derate;
4. Support digital potentiometer speed adjustment, fast and accurate speed adjustment;
5. Complete protection functions: multiple protections such as short circuit, overcurrent, overvoltage, overload, and overheating.



Model and Product List

EM700 -4R0-3B

① ② ③ ④



Product Series

EM700: EM700 Inverter

Adapted Load Power

OR7	1R5	2R2	4R0	5R5
0.75kW	1.5kW	2.2kW	4.0kW	5.5kW

Input Voltage level

2: Three-phase 220V
3: Three-phase 380V

B: Built-in braking unit
None: Without braking unit

Product List

RATED VOLTAGE OF POWER SUPPLY:
SINGLE-PHASE/THREE-PHASE
AC 200V~240V

RATED VOLTAGE OF POWER SUPPLY:
THREE-PHASE
AC 340~460V

Model	Applicable motor power (kW)	Heavy load rated output current (A)	Light load rated output current (A)
EM700-0R4-2B	0.4	2.8	3.2
EM700-0R7-2B	0.75	4.8	5
EM700-1R5-2B	1.5	8	8.5
EM700-2R2-2B	2.2	10	11.5
EM700-0R7-3/3B	0.75	2.5	3
EM700-1R5-3/3B	1.5	4.2	4.6
EM700-2R2-3/3B	2.2	5.6	6.5
EM700-4R0-3/3B	4	9.4	10.5
EM700-5R5-3/3B	5.5	13	15.7

Standard Wiring Diagram of Control Circuit

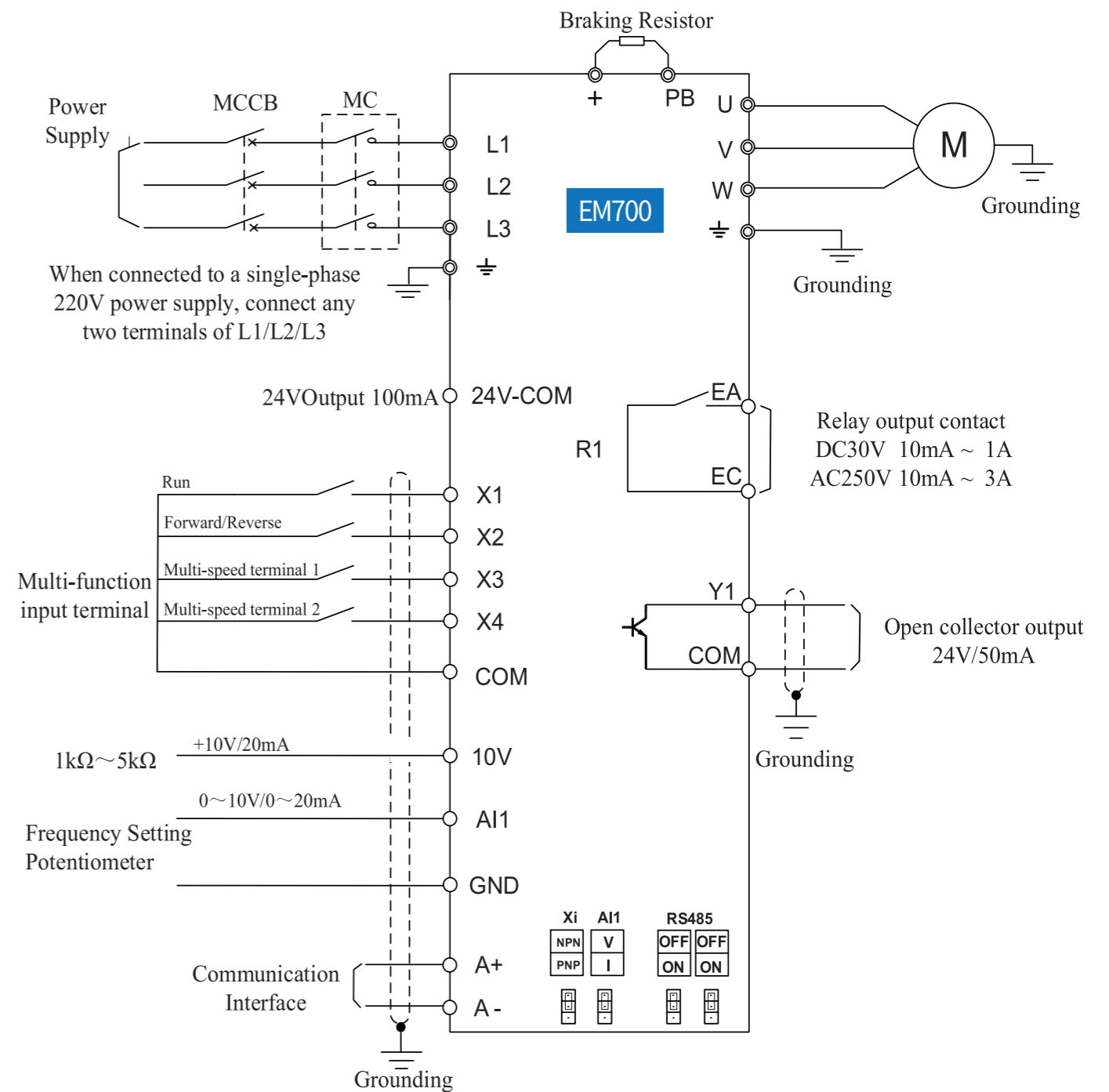

EM700

Technical Specification



POWER SUPPLY

Item	Specification
Rated supply voltage	Three-phase 340V-10%~460V+10% Single-phase/three-phase 200V-10%~240V+10% 50~60Hz±5%, voltage imbalance rate <3%



OUTPUT

Item	Specification
Maximum output voltage	The maximum output voltage is the same as the input supply voltage
Output current rating	100% rated current continuous output
Maximum overload current	150% heavy load rated current for 60s; 120% light load rated current for 60s



BASIC CONTROL FUNCTIONS

Item	Specification
Driving mode	V/F control (VVF); Speed sensorless vector control (SVC);
Input	Frequency (speed) input, torque input
Start and stop control mode	Keyboard, control terminal (two-line control and three-line control), communication
Frequency control range	0.00~600.00Hz/0.0~3000.0Hz
Input frequency resolution	Digital input: 0.01Hz/0.1Hz; Analog input: 0.1% of maximum frequency
Speed range	1:50 (VVF), 1:200 (SVC)
Speed control accuracy	±0.2% rated synchronous speed
Acceleration and deceleration time	0.01s to 600.00s/0.1s to 6000.0s/1s to 60000s
Voltage/frequency characteristics	Rated output voltage is adjustable from 20% to 100%; Fundamental frequency 1Hz~600Hz/3000Hz adjustable
Torque boost	Fixed torque boost curve, Any V/F curve optional
Starting torque	150%/1Hz (VVF) 、 150%/0.25Hz (SVC)
Torque control accuracy	±5% rated torque (SVC)
Output voltage self-adjusting	As the input voltage changes, the output voltage remains basically the same
Automatic current limiting	Automatically limit output current to avoid frequent overcurrent protection actions
DC braking	Braking frequency: 0.01~maximum frequency Braking time: 0~30S Braking current: 0%~150% rated current
Signal input source	Communication, multi-speed, analog, etc.



INPUT AND OUTPUT FUNCTIONS

Item	Specification
Reference power supply	10V/20mA
Terminal control power	24V/100mA
Digital input terminal	4 digital multi-function inputs: X1~X4
Analog input termin	1 analog input 1 channel (AI1) voltage source 0~10V, 0-5V input or current source 4~20mA input optional
Digital output terminal	1 open collector multi-function output and 1 relay multi-function output Collector output maximum output current 50mA Relay contact capacity 250VAC/3A or 30VDC/1A EA-EC normally open



KEYBOARD

Item	Specification
LED display	LED digital tube displays relevant information of the inverter



PROTECTION

Item	Specification
Protective function	Short circuit, overcurrent, overvoltage, undervoltage, phase loss, overload, overheating, load loss and external protection, etc.



CONDITIONS OF USE

Item	Specification
Installation place	Indoors, the altitude is less than 1 km, no dust, no corrosive gases and no direct sunlight. When the altitude exceeds 1,000 meters, the usage will be derated by 1% for every 100 meters higher, and the maximum usage altitude is 3,000 meters.
Applicable environment	-10°C~+50°C, 5%~95%RH (no condensation). When the ambient temperature exceeds 50°C, derating is required. The derating is derated by 3% for every 1°C increase. The maximum operating ambient temperature is 60°C
Vibration	Less than 0.5g
Storage environment	-40°C~+70°C
Installation method	Wall-mounted, cabinet installation



PROTECTION LEVEL

Item	Specification
Protection level	IP20



COOLING METHOD

Item	Specification
Cooling method	Forced air cooling

Dimension

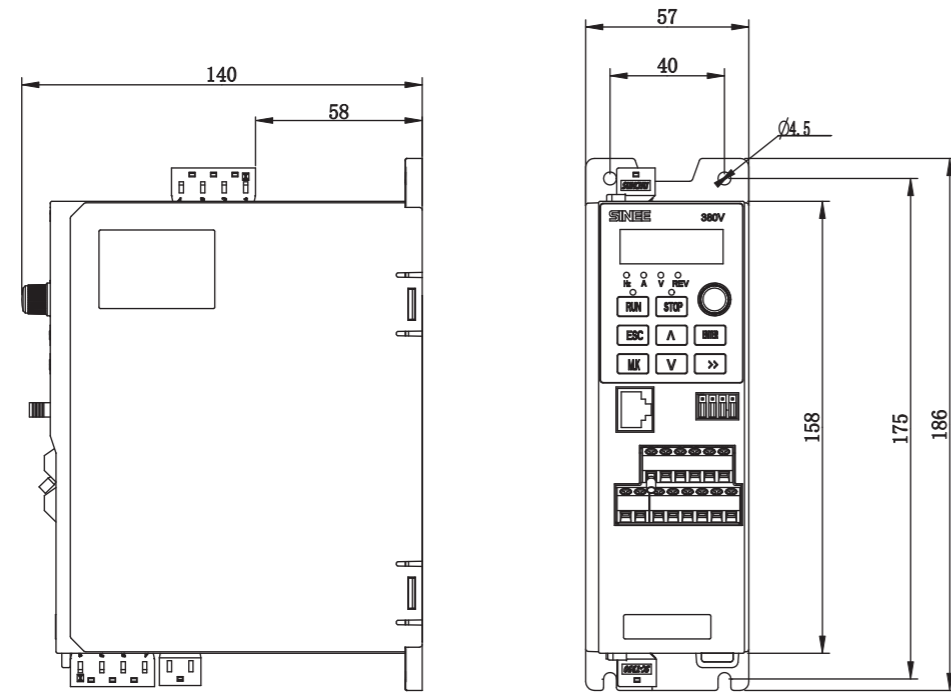

(a) E700-0R4-2B~EM700-0R7-2B/EM700-0R7-3B~EM700-1R5-3B Size

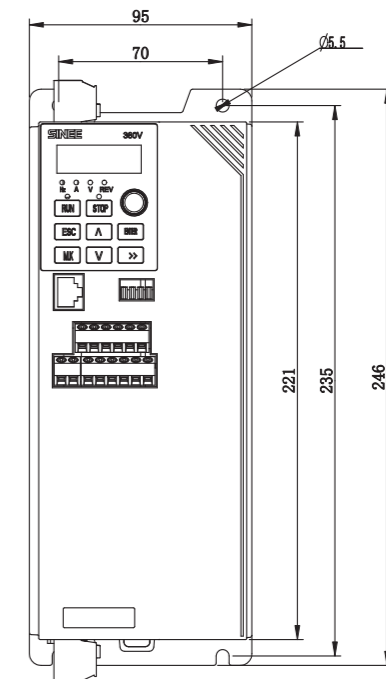
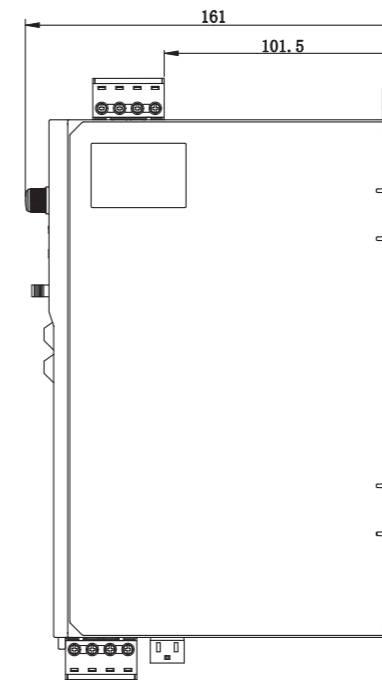

1:2

(c) E700-5R5-3B Size

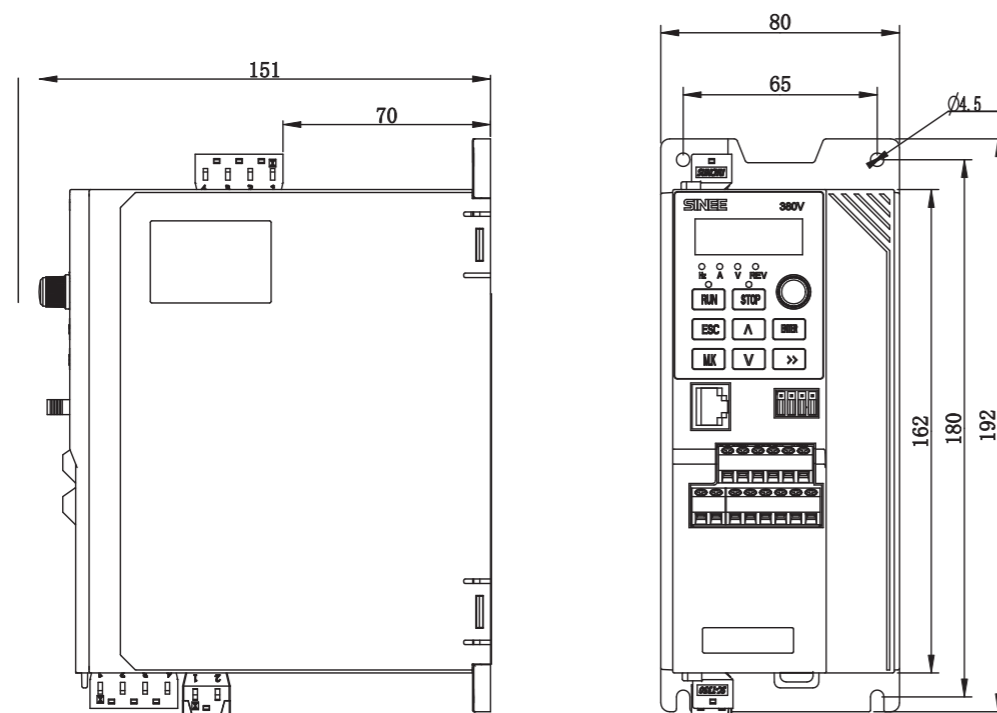

(b) E700-1R5-2B~EM700-2R2-2B/EM700-2R2-3B~EM700-4R0-3B Size

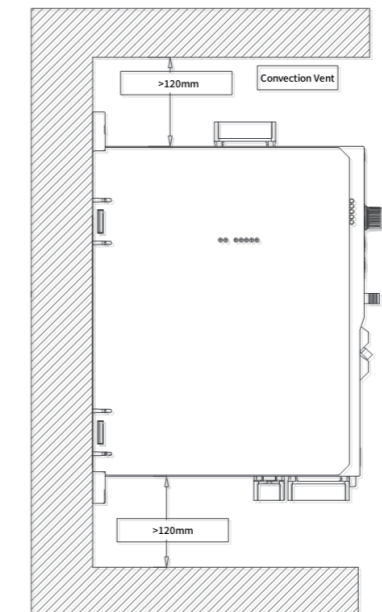

EM700 installation direction and space

BR100 Series Energy Consumption Braking Unit

The BR100 series braking unit has the stable and reliable working performance and protection against over-temperature and braking resistor short circuit, and can be used for inverter-driven lifting equipment, centrifuges, washing machines, spin dryers, and rapid parking. It can change the electric energy generated by the motor in the power generation state into the thermal energy to be used by the braking resistor. In addition, it is easy to use and compatible with inverters of various brands.

Model and specification	Application	Minimum Resistance (Ω)	Average Braking Current I_{av} (A)	Peak Current I_{max} (A)	Applicable Inverter Power (kW)
BR100-045	Energy consumption braking	10	45	75	18.5~45
BR100-160		6	75	150	55~160
BR100-200		5	100	200	160~200
BR100-315		3	120	300	220~315
BR100-400		3	200	400	315~400
BR100-220-6		6	120	200	160~250



Note: With the minimum resistance, the BR100 braking unit can work continuously at the braking frequency $D \leq 33\%$. In the case of $D > 33\%$, it should work intermittently; otherwise, the over-temperature protection fault may occur.

Product model and size

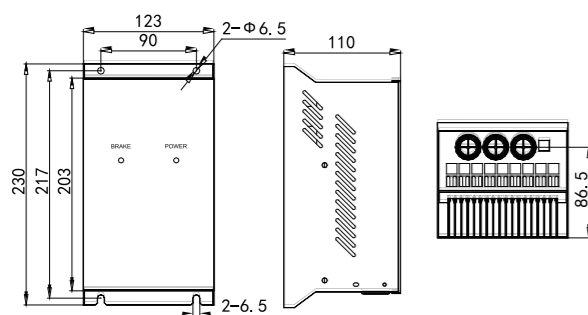

Dimensions of BR100-045 braking unit

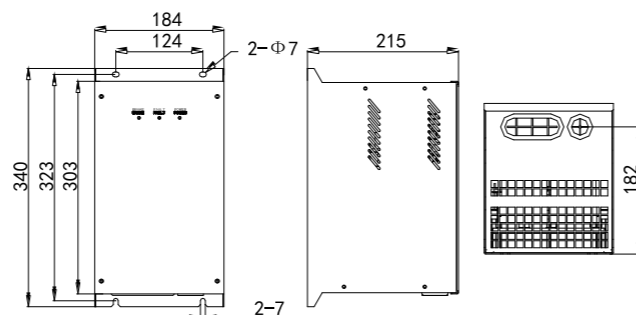

Dimensions of BR100-160\BR100-200 braking unit

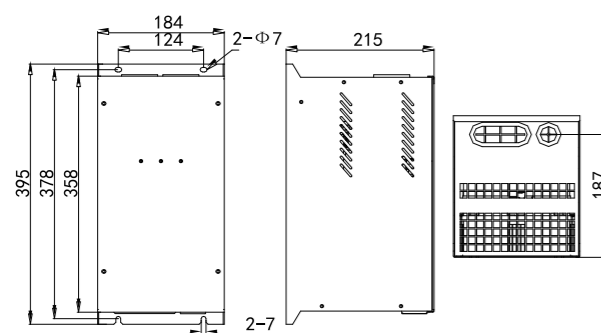

Dimensions of BR100-315\BR100-400 braking unit

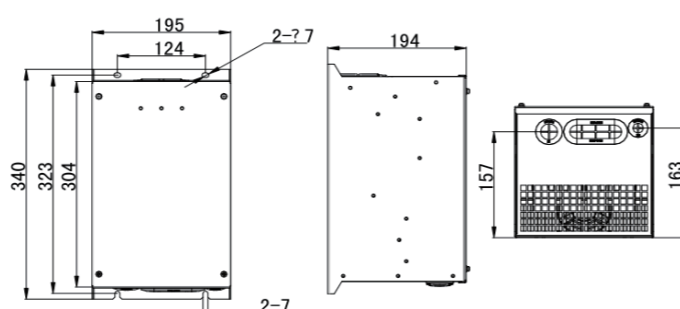

Dimensions of BR100-220-6 braking unit