

(1-10kVA) Series UPS User Manual

Foreword

Summaries

Thank you for choosing the uninterruptible power system (hereinafter referred to as UPS)!

This document gives a description of the (1-10kVA) series UPS, including the features, performance, appearance, structure, working principles, installation, operation, maintenance, transportation and storage, etc.

Please save the manual after reading, in order to consult in the future.

**NOTE**



The figures in this manual are just for reference, for details please see the actual product.





Suitable Model

- 1kVA、1kVA (L)
- 2kVA、2kVA (L)、3kVA、3kVA (L)
- 6kVA (L)、10kVA、10kVA (/B)

Symbol Conventions

The manual quotes the safety symbols, these symbols used to prompt users to comply with safety matters during installation, operation and maintenance. Safety symbol meaning as follows.

Symbol	Description
 DANGER	Alerts you to a high risk hazard that could, if not avoided, result in serious injury or death.
 WARNING	Alerts you to a medium or low risk hazard that could, if not avoided, result in moderate or minor injury.

Symbol	Description
 CAUTION	Alerts you to a potentially hazardous situation that could, if not avoided, result in equipment damage, data loss, performance deterioration, or unanticipated results.
	Anti-static prompting.
	Be care electric shock prompting.
 TIP	Provides a tip that may help you solve a problem or save time.
 NOTE	Provides additional information to emphasize or supplement important points in the main text.

Product standard: Q/ZZKJ 001

Change History

Changes between document issues are cumulative. The latest document issue contains all the changes made in earlier issues.

Issue 001 (2018-09-20)

First issue.

Contents

1 Safety Description.....	1
1.1 Safety Announcements.....	1
1.1.1 Use Announcements.....	1
1.1.2 Battery Announcements.....	2
1.2 Operation and Maintenance Requirements.....	3
1.3 Working Environment Requirements.....	3
2 Overview.....	5
2.1 Product Intro.....	5
2.1.1 Model Meaning.....	5
2.1.2 Features.....	5
2.2 Appearance and Structure.....	6
2.2.1 appearance.....	6
2.2.1 Operation Panel.....	8
2.2.2 Rear Panel.....	10
2.3 Communication.....	11
2.4 Intelligent Slot.....	12
2.5 EPO Connector.....	12
2.6 Working Principles.....	13
3 Installation.....	14
3.1 Unpacking and Checking.....	14
3.2 Cable and Breaker Selection.....	14
3.2.1 Cable Selection.....	14
3.2.2 Input Breaker Selection.....	14
3.3 Install UPS.....	15

3.4 Intelligent Slot Installation	16
3.5 Electrical Connection	17
4 Operation and Maintenance	20
4.1 Check Before Startup	20
4.2 Startup Operation	20
4.2.1 1kVA(L), 2kVA(L), 3kVA(L).....	20
4.2.2 6kVA(L)、 10kVA (/B).....	21
4.3 Shutdown Operation.....	21
4.3.1 1kVA(L)、 2kVA(L)、 3kVA(L).....	21
4.3.2 6kVA(L) 、 10kVA (/B).....	21
4.4 Periodic Preventative Maintenance	22
4.5 Battery Maintenance	22
4.6 Troubleshooting.....	22
A Technical Specifications	26
B Acronyms and Abbreviations	31

1 Safety Description

This chapter mainly describes the safety announcements. Prior to performing any work on the UPS, please read the user manual carefully, follow the operation and installation instructions and observe all danger, warning and safety information, which is to avoid human injury and device damage by irregular operations.

1.1 Safety Announcements

This section mainly describes the safety announcements when operation and maintenance. For details, please refer to safety description in the relevant chapters.



CAUTION

Before using the UPS, please read the announcements and operation instructions in this section carefully to avoid accident.

The promptings in the user manual, such as "Danger", "Warning", "Caution", etc. DO NOT include all safety announcements. They are just the supplement of safety announcements when operation.



NOTE

Any device damage caused by violating the general safety operation requirements or safety standards of design, production, and usage will be out of warranty range.

1.1.1 Use Announcements



DANGER

There exists high temperature and high voltage inside the UPS. When using UPS, please strictly comply with all warnings and operation instruments on the UPS and in the user manual.

**CAUTION**

No liquid or other object is allowed into the UPS.

**CAUTION**

The UPS is a class A product. When it is applied to residential building, additional measures should be taken to prevent wireless interference.

**WARNING**

Do not connect unbalanced load, half-wave rectification load or inductive load to the output of the UPS, such as air-condition, blower, starter, electric drill, motor, daylight lamp, etc.

**WARNING**

In case of fire, use dry powder extinguisher to put out the fire. If you use liquid fire extinguisher, it may cause electric shock.

**CAUTION**

UPS must be well grounded.

1.1.2 Battery Announcements

**WARNING**

Only authorized professional can replace battery. When operation, take off conductive objects, such as watch, bracelet, bangle, ring, etc., wear rubber shoes and gloves and use tools with insulated handle.

- Don't put tools or other conductive objects on the battery.
- It's prohibited to connect the anode with the cathode of battery or connect them reversely, which is to avoid fire or electric shock.
- Before connecting or disconnecting the battery terminals, disconnect charging power first.
- Do not use the battery with different type, different model or different manufacturer together.
- Battery should be kept away from fire source or any electrical equipment that may easily cause spark to avoid human injury.
- Don't open or destroy the battery. The electrolyte in the battery includes some dangerous objects, such as strong acid, which will be harmful to skin and eyes. If touching the electrolyte by accident, please clean it by a lot of water immediately and then see the doctor.
- The waste battery should be disposed according to the local regulations.

1.2 Operation and Maintenance Requirements



CAUTION

Only authorized professionals are allowed to open the UPS chassis, or it may cause electric shock and the caused UPS fault is out of the guarantee range.

- If UPS needs to be moved, rewired or maintained, disconnect all electrical connection, such as AC power, battery power, etc. to isolate power input. Do not do any work on the UPS until it is powered off completely(≥ 10 min). Otherwise, the output may have electricity, which may cause electric shock.
- When dismantling fan, do not put fingers or tools into the rotating fan to avoid device damage or human injury.

1.3 Working Environment Requirements

- Don't install UPS where it would be exposed to direct sunlight, in rain or in moist environments.
- Don't install UPS where it is with conductive metal dust or nearby heater.
- Generally, the working temperature of the UPS is $-5^{\circ}\text{C} \sim +40^{\circ}\text{C}$ and the relative humidity is $0\% \text{RH} \sim 95\% \text{RH}$ with no condensation (The recommended working temperature is $20^{\circ}\text{C} \sim 25^{\circ}\text{C}$ and the recommended relative humidity is about 50%).

- Put UPS in the flat floor without vibration and the vertical gradient is less than 5° . Keep good ventilation around the UPS. The clearance between the rear or the side of UPS and adjacent devices or wall should be at least 300mm~500mm. Poor ventilation will rise temperature inside the UPS, which will reduce the working life of inner components and then affect the working life of UPS.
- The recommended altitude is lower than 1000m. If exceeding 1000m, it needs to decrease the rated power according to GB3859.2-93 to use.

2 Overview

This chapter mainly describes the model meaning, features, structure and working principle, etc.

2.1 Product Intro

The (1-10kVA) series UPS are with all high frequency, pure online, double-conversion, intelligent features. They are the perfect power security for file server, enterprise server, center server, mirco-computer, concentrator, telecom system, data center and others that require high quality power protection. They are widely applied to the many key business areas, such as post, finance, network, stock, railway, etc.

2.1.1 Model Meaning

UPS that the output power is less than 10kVA

The "L" means long backup model. If there is no "L" symbol, it means standard model.

For the 2-3kVA standard model UPS, it also includes a UPS and a battery box.

For 6kVA(L) UPS, it just has long backup model.

UPS that the output power is not less than 10kVA

The "L" means long backup model. If there is no "L" symbol, it means standard model.

The“/B”means it can be used in parallel model.If without “/B”,it means the UPS can be used in single mode.

The 10kVA(/B) UPS just has long backup model.

2.1.2 Features

Intelligent RS232 communication

By the RS232 standard data port and UPS power management software, it can realize the three remote function between the computer and UPS, monitor the running and electrical data of the UPS on the computer, perform ON/OFF operation remotely and it also supports SNMP network adaptor (external, connect with UPS through RS232), which makes UPS be a network new member.

High input power factor

Adopt advanced active PFC technology to ease the load to power grid. It is the new generation green power.

High cost performance

Adopt many kinds of power conversions and high frequency PWM technologies, which make the UPS with high efficiency, small volume, light weight, and improves the running reliability and reduces cost.

Perfect protection

With the protection for output over-voltage, battery under-voltage, input over-voltage triple over-current, etc. and solved the problems of bad adaptability for power grid and weak shock resistance.

Low mains input voltage

Adopt the independent rapid detection technology. When the mains input voltage is 120V, which is the lower limit, the battery still doesn't discharge. Therefore, in the mains mode, all output power gets from the power grid, which is to ensure the battery still in the 100% energy storage status, and at the same time, reduce the battery discharge times and prolong the working life.

2.2 Appearance and Structure

2.2.1 appearance

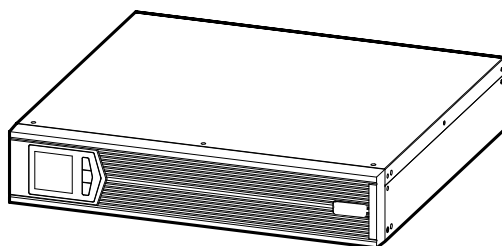

Figure2-1 UPS appearance

For 2-3kVA standard backup model, besides UPS host, we will provide a battery box, for 1 kVA(L), 2-3kVA(L) long backup model, the battery box can be provided according to use needs. The corresponding battery box appearance is as shown in Figure2-2.

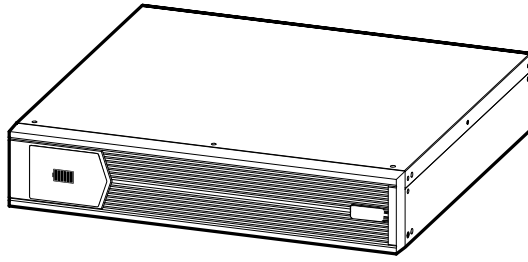

Figure2-2 Battery box appearance of 2-3kVA

For 6kVA(L), 10kVA(B) model, the battery box can be provided according to use needs, corresponding battery box appearance is as shown in Figure2-3.

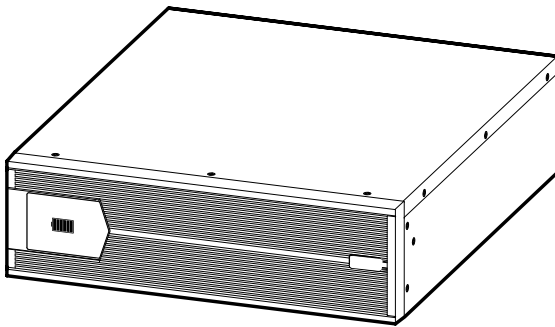

Figure2-3 Battery box appearance of 6kVA(L), 10kVA(B)



NOTE

The battery box amount of long backup model is different on the basis of required backup time. The relationship between battery box and UPS is as shown in Table2-1.

Table2-1 Relationship between UPS and battery box

UPS model	Battery box model
1kVA(L)	48VDC
2kVA	48VDC
2kVA(L)	72VDC
3kVA	72VDC
3kVA(L)	96VDC
6kVA(L)	192VDC
10kVA	

10kVA (/B)	
------------	--

2.2.1 Operation Panel

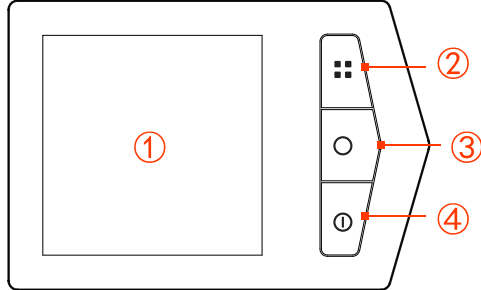

Figure2-4 Operation panel

Table2-2 The illustration of operation panel

No.	Name	Illustration
①	LCD	Shows the working status, battery backup capacity and fault alarm, alarm.
②	"■ ■" button	<ul style="list-style-type: none"> ● Short press "■ ■" button, the LCD shows the output voltage, output frequency, input voltage, input frequency, battery voltage, UPS temperature, output load percentage, fault information, etc. circularly. ● Long press "■ ■" button for 5s, the LCD will enter setting page. Short press "■ ■" to select the setting command, long press "Ⓢ" button to confirm the command.
③	"○" button	When UPS is on, long press "○" button for 1s, the UPS will be turned off.
④	"Ⓢ" button	<ul style="list-style-type: none"> ● When UPS off, long press "Ⓢ" button for 1s, the UPS starts. ● When UPS on, at mains mode, long press "Ⓢ" button for 3s, the UPS start to perform battery test. ● At battery mode, long press "Ⓢ" button for 3s to mute the buzzer (cancel mains abnormal alarm).

LCD panel

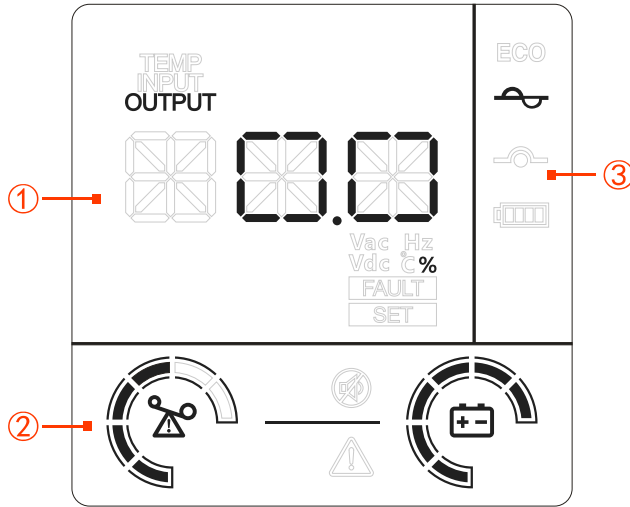





Figure2-5 LCD panel

The illustration for the LCD panel is as shown in Table2-3.

Table2-3 The illustration of LCD panel

NO.	Name	Illustration
①	Running status display area	Shows the input, output, temperature, fault type and setting, etc. of the UPS.
②	Output status display area	Shows the load capacity, battery capacity, fault indication and buzzer silence, etc.
③	Work mode display area	Shows the UPS work status: mains inverter(), bypass power supply(), battery inverter(), ECO (ECO)

 **NOTE**

Fault model and corresponding dispose please see Table4-2.

2.2.2 Rear Panel

1kVA(L)

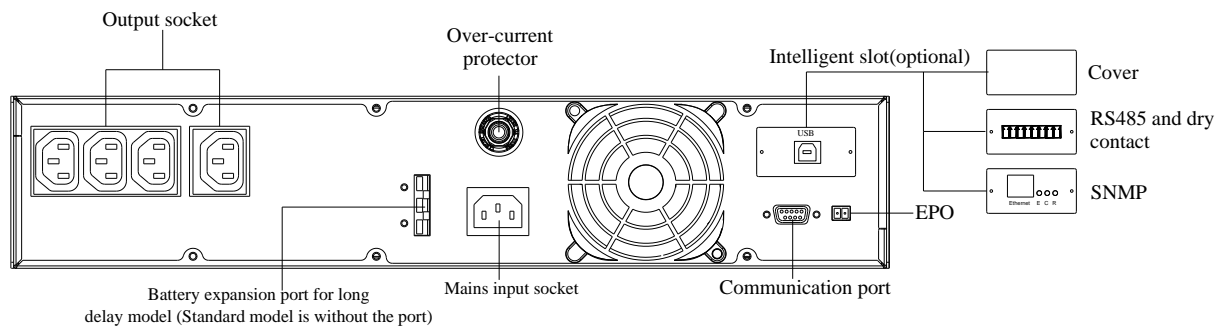

Figure2-6 Rear panel of 1kVA(L)

2-3kVA(L)

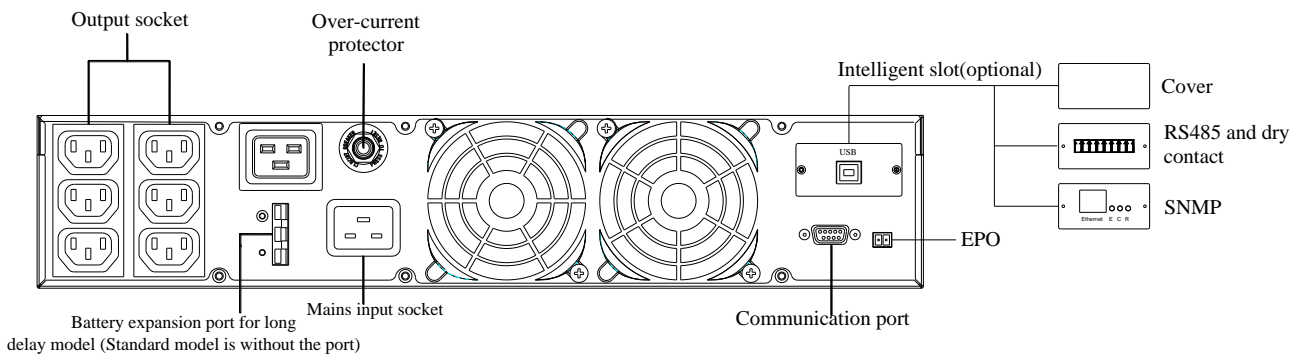

Figure2-7 Rear panel of 2-3kVA(L)

6kVA(L), 10kVA(/B)

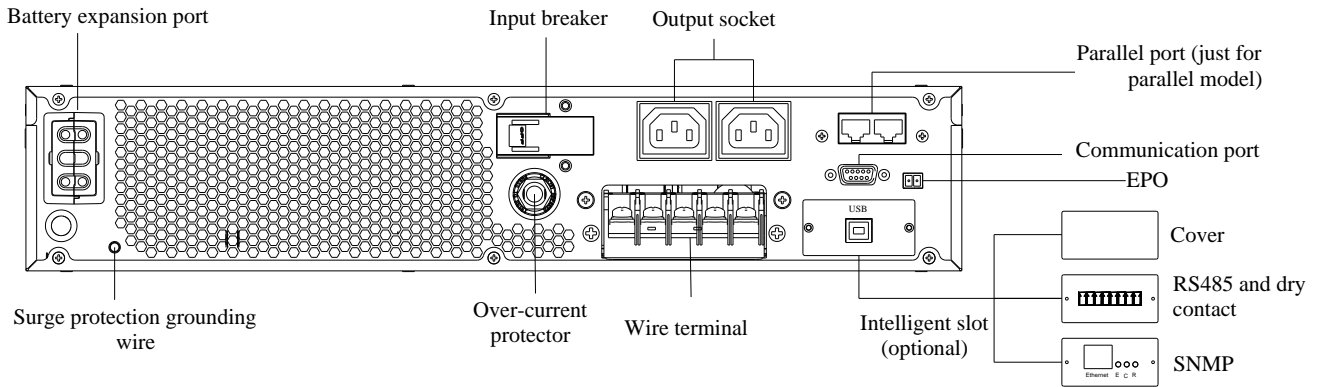

Figure2-8 Rear panel of 6kVA(L)、 10kVA(/B)

2.3 Communication

1kVA(L), 2kVA(L), 3kVA(L),6kVA(L), 10kVA(/B) adopt RS232 series port to communicate with PC. The corresponding pin relationship of RS232 port between UPS and PC is as shown in Table2-4.

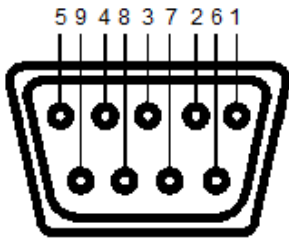

Table2-4 The corresponding pin relationship of RS232 port between of UPS and PC

RS232 port of UPS	RS232 port of PC
9 (3)	2 (receiving end)
6 (2)	3 (transmitting end)
7 (5)	5 (grounding end)

2.4 Intelligent Slot

RS485 and dry contact(optional)

The pin sequence and pin definition of RS485 and dry contact is as shown in Figure2-9 and Figure2-10.

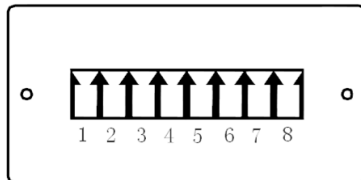

Figure2-9 RS485 and dry contact

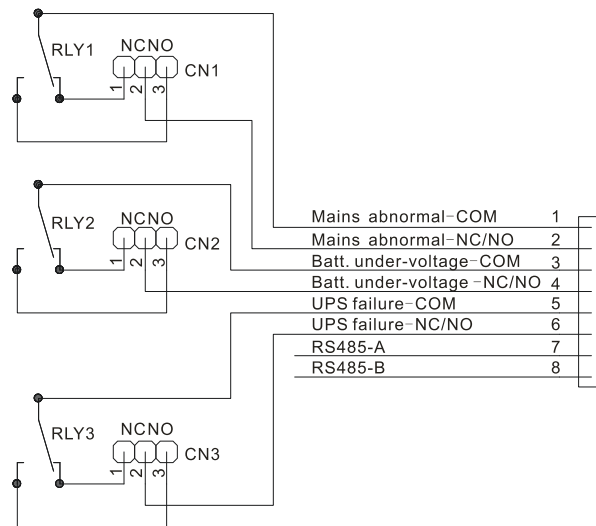

Figure2-10 Pin definition of RS485 and dry contact

The illustration of dry contact is as below:

1. CN1, CN2, CN3 determine that dry contact output signal is normal open or normal close. In default, dry contact output signal is normal close, that is PIN1 connects with PIN2. If one route signal needs to set to normal open, connect PIN2 with PIN3.
2. The requirements for input signal of dry contact: the voltage should be less than 60Vdc or 42Vac RMS and the current should be less than 1.25A.

2.5 EPO Connector

When connecting two ports in the EPO connector together, UPS will close output. If it needs to recover output, disconnect two ports in the EPO connector and power UPS off, and then restart UPS.

2.6 Working Principles

When the mains is normal, the input of the UPS is converted into the $\pm 360\text{V}$ steady DC voltage through PFC, which supplies power for DC/AC inverter to output steady 220V AC and charges battery at the same time. When the mains is abnormal, the battery will boost into the $\pm 360\text{V}$ DC voltage for DC/AC inverter through DC/DC.

The working principles of the (1-10kVA) series UPS is as shown in Figure2-11, Figure2-12. The DC/AC inverter adopts half-bridge structure and the DC/DC boost adopts the quasi push-pull circuit or boost circuit. PFC is the active power factor correction circuit, CHARGER is completely isolated charger.

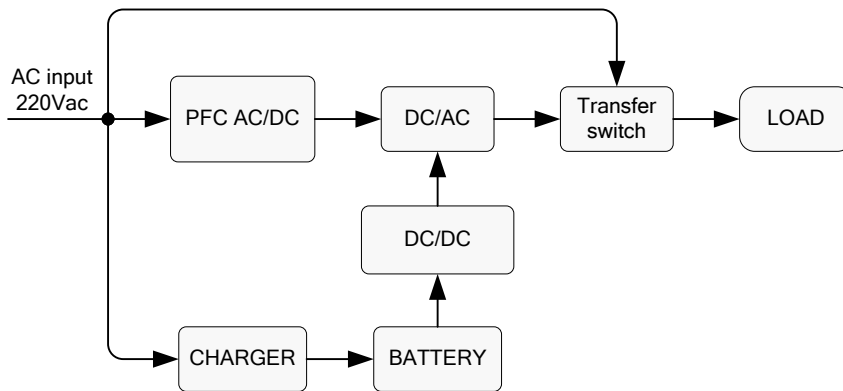

Figure2-11 Work principle of 1-3kVA(L)

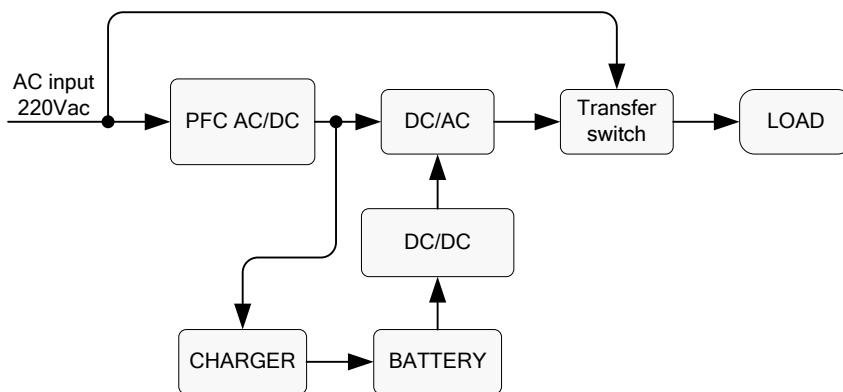

Figure2-12 Work principle of 6kVA(L) 、 10kVA(B)

3 Installation

This chapter mainly describes the UPS installation, including unpacking and checking, installation preparation, electrical connection, etc.

3.1 Unpacking and Checking

Unpacking the UPS and check the following items:

- Inspect the UPS appearance and check if there is any shipping damage, if any damage is found, report it to the carrier immediately.
- Check the delivery list to see if the types of accessories are complete and correct. If there is any discrepancy, contact the distributor immediately.

3.2 Cable and Breaker Selection

3.2.1 Cable Selection

For the selection of the cross-sectional area of AC input wire, AC output wire and battery wire of the UPS, please refer to Table3-1 for the corresponding recommended value and choose upwards.

Table3-1 The recommended cross-sectional area of wire

Cross-sectional area (mm ²)		1	1.5	2.5	4	6	10	16	25
Current-carrying capacity (A)	Rubber (25°C)	8	12	20	28	42	70	96	125
	Plastic (25°C)	6	9	15	20	30	50	64	100

3.2.2 Input Breaker Selection

Add a breaker (It's recommended that the breaker is with feedback protection and bipolar disconnection function) or a power distribution box at the front of the input wire of the UPS, which matches with the UPS power, to isolate the mains. Considering the charging power of the UPS and the transient current impact when power on, the current of the selected breaker should be 1.5~2

times of the max. input current of UPS. Besides, the selected breaker cannot with the leakage protection to avoid mis-operation. The distribution box is better to be made by the professional company. The selection of input breaker refers to Table3-2.

Table3-2 Recommended input breaker specification

	1kVA(L)		2kVA(L)		3kVA(L)		6kVA(L)		10kVA (/B)	
	Max. current	Break er	Max. current	Break er	Max. current	Break er	Max. current	Break er	Max. current	Break er
AC input (A)	6	10	12	20	18	32	36	50	60	100
DC input (for long backup model) (A)	37	50	37	50	42	50	39	50	65	100

3.3 Install UPS

NOTE

The installation for the UPS and the battery box is the same, in this section, we take the UPS installation as an example to illustrate.

Step 1 Fasten the two angle irons onto the two sides of the UPS by 4 sunk screws, as shown in Figure3-1.

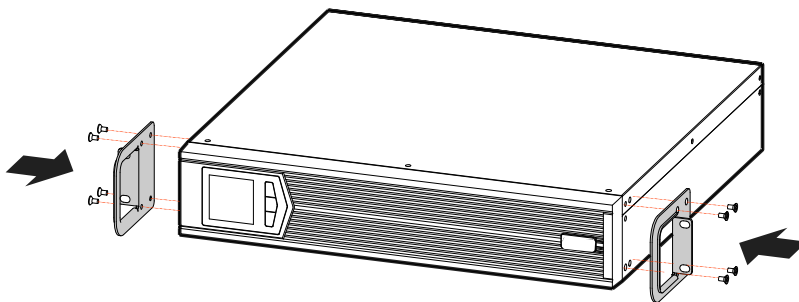

Figure3-1 Install angle iron

Step 2 Push the UPS into the cabinet, and fasten it by screws, as shown in Figure3-2.

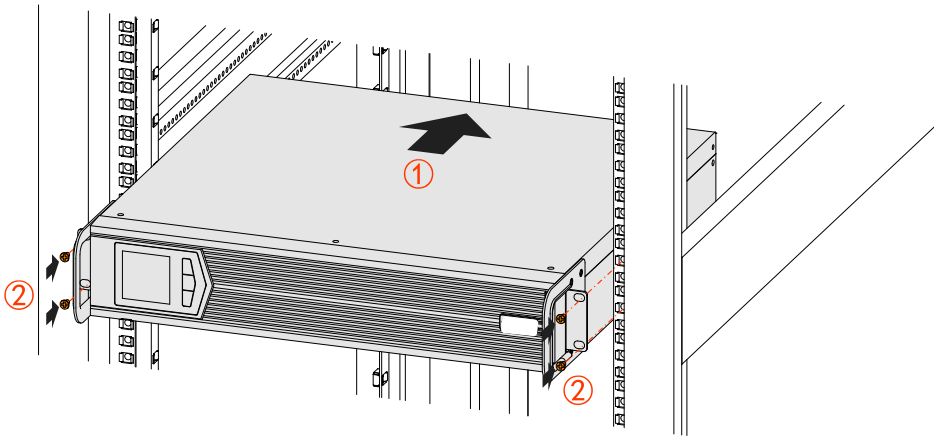

Figure3-2 Fasten the UPS

**CAUTION**

The battery box is heavy, when installing, the battery box must be installed down below the UPS.

----End

3.4 Intelligent Slot Installation

Step 1 Dismantle standard intelligent slot.

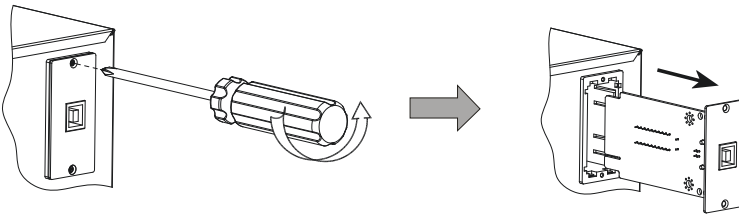

Figure3-3 Dismantle standard intelligent slot

Step 2 Install optional intelligent slot and fix it.

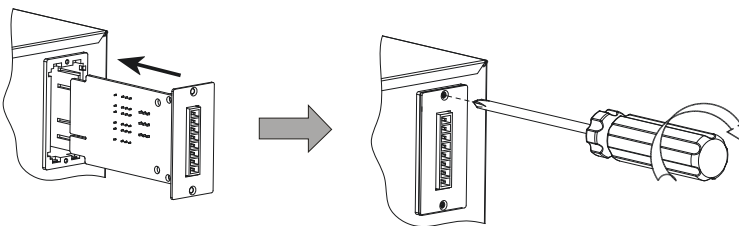

Figure3-4 Install optional intelligent slot

Step 3 Connect communication cable.

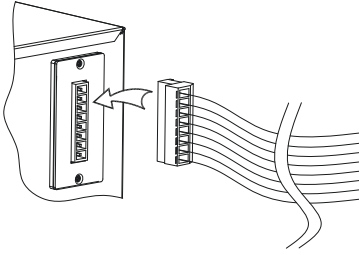

Figure3-5 Connect communication cable

----End

3.5 Electrical Connection

The UPS and battery box is the rack DC power supply unit for 19inch cabinet, the battery is connected to the UPS via battery port.



WARNING

Ensure all the breakers that connect with the UPS are disconnected and after the UPS installed properly, the electrical connection can be done.

- For standard backup UPS, the backup time cannot be expanded, for long backup UPS, the backup time can be expanded on the basis of needs.
- The DC input voltage of the UPS must match the voltage of battery box.
- For long backup UPS, it also needs to connect with battery by battery expansion wire, that is to say, insert the battery plug of the battery box to the socket of the UPS.

The input and output connection of the UPS is as shown in Figure3-6 to Figure3-8.

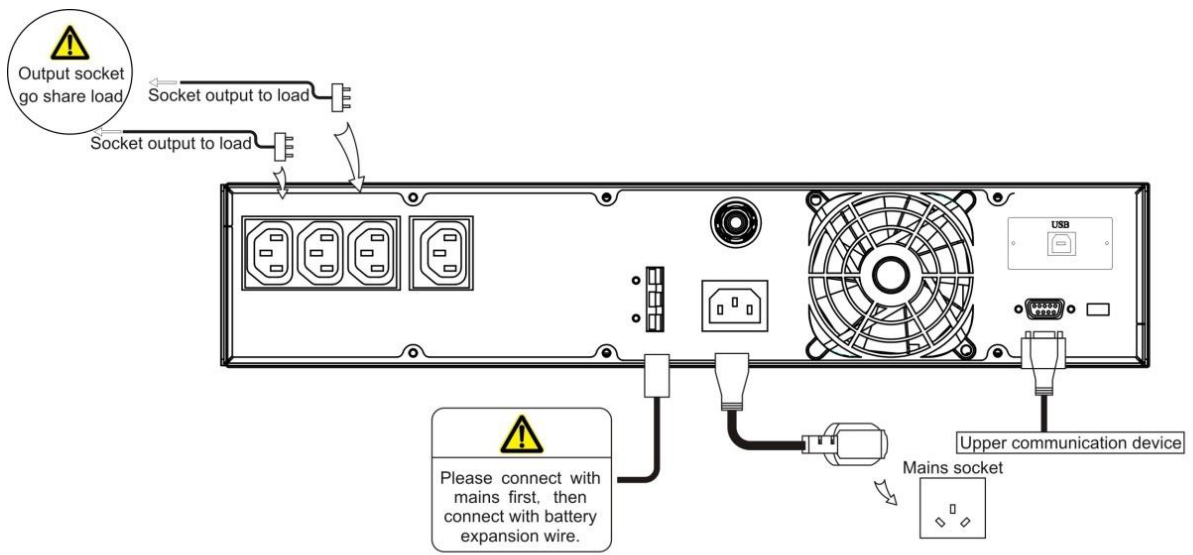

Figure3-6 Wiring diagram of 1kVA(L)

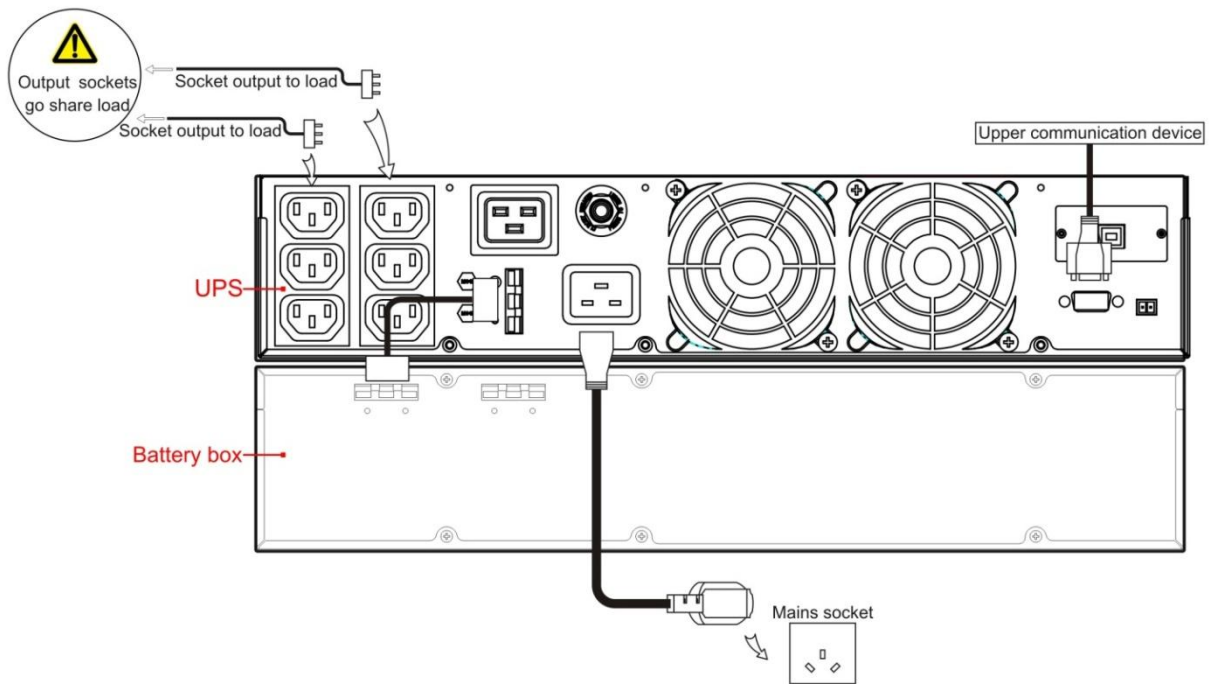

Figure3-7 Wiring diagram of 2-3kVA(L)

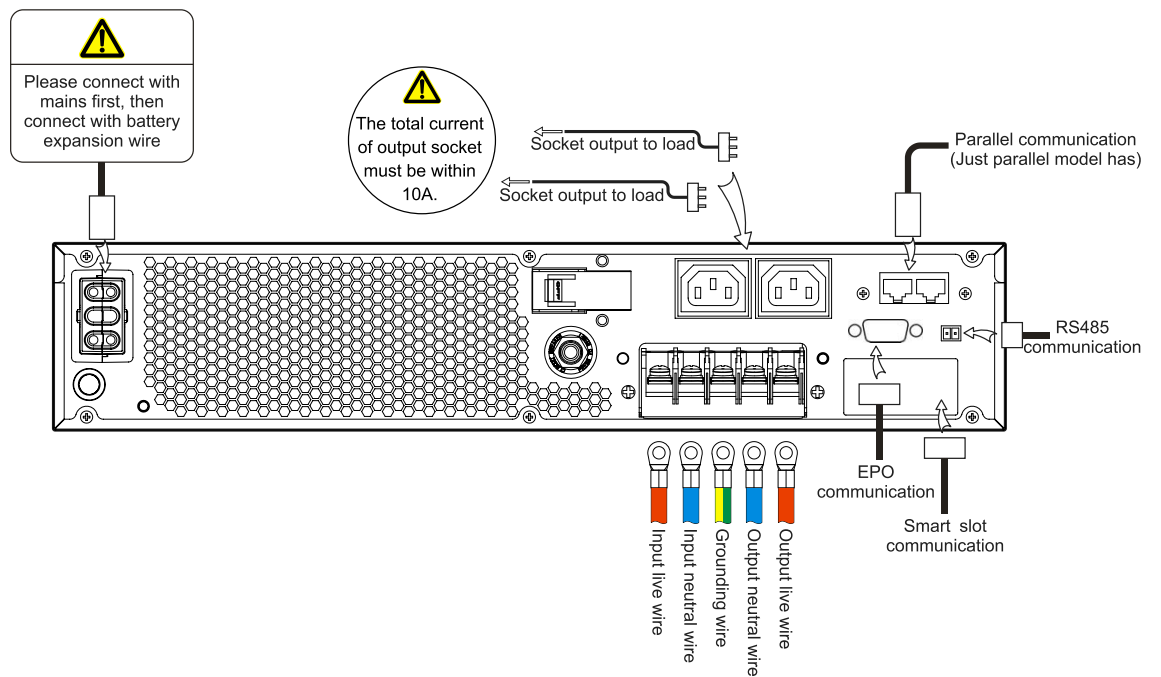

Figure3-8 Wiring diagram of 6kVA(L), 10kVA (/B)



CAUTION

- Mains socket should be near by the UPS and easy to operate.
- For long backup model, connect the UPS with mains first and then insert the battery expansion wire.
- Generally, the load current of each output socket should be not more than 10A.

4 Operation and Maintenance

This chapter mainly describes the operation process, operation method, daily maintenance and troubleshooting, etc.

4.1 Check Before Startup

- Check if the wire connection is firm and the color of AC wires is in accordance with the specification.
- Check if UPS is grounded reliably.
- Check if the voltage between the neutral wire and grounding wire is less than 5Vac.
- If the UPS equipped with remote monitoring device, check if the wiring of the RS232 port is correct.
- If it is long backup model, check if the wiring between UPS and battery box is correct and reliable.
- Check if the wiring is neat and the wire binding is in accordance with the specification.
- Check if the installation and wiring are good for transformation, expansion and maintenance in future.
- Check that there is no short-circuit in the output of the UPS and the load capacity isn't beyond the rated capacity of the UPS.

4.2 Startup Operation

4.2.1 1kVA(L), 2kVA(L), 3kVA(L)

- Step 1 Insert the mains socket of the UPS.
- Step 2 Press "①" button on the panel for 1s to start the UPS.
- Step 3 About 10s later, if the UPS works steadily, start loads, such as PC, etc.

**CAUTION**

Start load according to "high power device → small power device", which is to avoid overload protection when starting high power device.

----End

4.2.2 6kVA(L)、10kVA (/B)

- Step 1 Switch on the mains input breaker.
- Step 2 Press "ⓘ" button on the panel for 1s to start UPS.
- Step 3 About 10s later, if the UPS works steadily, start loads, such as PC, etc.

**CAUTION**

Start load with the sequence that "high power device → small power device", which is to avoid overload protection when starting high power device.

----End

4.3 Shutdown Operation

4.3.1 1kVA(L)、2kVA(L)、3kVA(L)

- Step 1 Close load and keep the UPS running without load for about 10min to exhaust heat.
- Step 2 Press "⓪" button on the panel for 1s.
- Step 3 Unplug mains socket.

----End

4.3.2 6kVA(L)、10kVA (/B)

- Step 1 Close load and keep UPS running without load for about 10min to exhaust heat.
 - Step 2 Press "⓪" button on the panel for 1s.
 - Step 3 Switch off the mains input breaker.
-

----End

4.4 Periodic Preventative Maintenance

To improve the efficiency and reliability of the UPS, perform the following maintenance regularly.

- Clean the UPS by dry cloth regularly. Don't use liquid or spray cleaner. Before cleaning, shut down the UPS.
- Check if the wiring of input and output is firmly and connect well.
- Check the working status of cooling fans regularly. Prevent sundries from blocking the air outlet. If damaged, please replace it in time.
- Check the battery voltage and the working status of UPS regularly.

4.5 Battery Maintenance

The working life of battery is based on the environment temperature and discharge times. Using battery in the high temperature for a long time or discharging battery deeply will reduce the working life of battery.

- Charge the battery for 10 hours before using. During charging, the UPS still can be used, but if power outage at the same time, the discharging time may be less than the standard value.
- Generally, charge and discharge the battery once every 4 to 6 months. Discharge the battery till under-voltage and power off and then charge it. In high temperature area, charge and discharge the battery once every 2 months. The charging time for the standard battery should be more than 10 hours every time.
- If the UPS hasn't been used for a long time, it is recommended to charge the battery more than 10 hours every three months.
- Generally, the working life of battery is 3 to 5 years. If battery is not so good, replace it in time. The battery replacement should be performed by authorized professional.

4.6 Troubleshooting

As shown in Table4-1, it only includes some common fault diagnosis. If any doubt, contact the local office or distributor for details.

Table4-1 Troubleshooting

Fault phenomenon	Possible reason
The mains normal. After starting the UPS, it outputs normally, but it works in the battery mode and the buzzer beeps intermittently.	<ol style="list-style-type: none"> 1) Check if the contactors and sockets in the input circuit are in good condition; 2) Check if the displayed input voltage amplitude or frequency of mains on the LCD is beyond the allowable range of UPS; 3) Check if the over-current protector in the rear panel is sprung. If yes, press the over-current protector switch.
After installing UPS, connecting with power will fuse the fuse or cause tripping operation.	UPS output is short circuit.
After starting, the LCD display and output are normal. But once connecting with load, it will stop outputting immediately.	<ol style="list-style-type: none"> 1) UPS is overload seriously or the output circuit is short-circuit. Please reduce load to proper capacity or find the short-circuit reason. The common reason is that the output changeover socket short-circuit or the input short-circuit after UPS damage. 2) The load is not started according to "high power device → small power device". Restart the UPS, and after the UPS works steadily, start high power load first, and then start small power ones successively.
Buzzer long beeps, fault indicator lights on, UPS works in bypass mode and inverter failure.	<ol style="list-style-type: none"> 1) The output is overload. The load is too heavy and beyond the rated power of the UPS. Please reduce load or select a UPS with larger power capacity. If it is temporary bypass caused by impact of load start and recovers automatically, it still is normal. 2) UPS over-temperature protection. Check if the air inlet and air outlet of UPS is blocked or the working temperature of UPS is beyond the allowable range.
Usually, UPS works normally. When power failure, it doesn't transfer to battery mode or it transfers to battery mode and	<ol style="list-style-type: none"> 1) Battery aging, the battery capacity loss. please replace battery. 2) Battery charger fault. At ordinary time, the battery

Fault phenomenon	Possible reason
battery under-voltage protection soon.	cannot be charged. 3) Battery wire doesn't connect well or the terminals contact is bad.
When the load is PC, everything works normally. When power failure, UPS works normally, but the computer system halted.	The grounding connection is not so good. The floating voltage between the neutral wire and the grounding wire is too high.

Table4-2 The meaning of fault symbol and buzzer status

Fault symbol		Buzzer status	Meaning
Fault info. page (page up or page down by " ■■ " button)	EPO	Long beep	UPS has emergency protection (if equipped with EPO function), Bypass output and inverting output are all closed.
	BUS	Long beep	The inner busbar voltage fault, the inverting output is closed.
	TMP	Long beep	UPS is over-temperature protected, the inverting output is closed. Please check if cooling fan is damaged or air vents are blocked.
	FAN	Rapid beep (Alarm once about every 0.5s)	Fan fault alarm prompting, the inverting output is going to protect. Please check if cooling fan is damaged or blocked.
		Long beep	Fan fault protection. The inverting output is closed.
	OUT	Long beep	Output fault, please check if output is short-circuit or the load is too large.
BAT	Long beep	Battery fault, battery voltage too low or too high protection.	
Load energy bars "25% ~ 100%, overload" all flicker	Rapid beep (Alarm once about every 0.5s)	Output overload alarm. The output is going to close, please reduce load.	

Fault symbol	Buzzer status	Meaning
Load energy bars “overload” light on	Long beep	Output overload protection, the output has been closed.
Load energy bars “short circuit” light on	Long beep	Output short circuit, the output has been closed.
Battery energy bar “25% ~ 100%, over-voltage” all flicker	Slow beep (Alarm once about every 2.0s)	Battery voltage is too high. Please check if battery or charger failure.
Battery energy bars “under-voltage” flickers	Rapid beep (Alarm once about every 0.5s)	Battery is about to run out. Please pay attention to protect the load and save the data of the PC.

**NOTE**

The above information is for user to know about some common fault diagnosis when UPS failure. If it may be inner components failure, please contact the professional.

A Technical Specifications

A.1 1kVA/(L), 2kVA/(L), 3kVA/(L)

Index \ Model		1kVA		2kVA		3kVA	
		1kVA	1kVA(L)	2kVA	2kVA(L)	3kVA	3kVA(L)
Input	Voltage range (V)	<p>When the voltage within the range of 176Vac~295Vac, the UPS can bear more than 75% load;</p> <p>When the voltage within the range of 154Vac-176Vac, the UPS can bear less than 75% load;</p> <p>When the voltage within the range of 120Vac~154Vac, the UPS can bear less than 50% load.</p>					
	Frequency range (Hz)	50/60±10% (50/60 self-adaption)					
	Input way	Single- phase three-wire					
	Battery voltage (V)	24	36	48	72	72	96
Output	Capacity (VA/W)	1000/900		2000/1800		3000/2700	
	Voltage (V)	220±2% (default) (can be set to 208/220/230/240)					
	Frequency (Hz)	50/60±0.2% (battery mode)					
	Wave form	Sine-wave					
	Voltage distortion	THD < 3% (linear load)					
	Power factor	0.9 (when the environment temperature lower than 30°C, the power factor can be set to 1.0 according to series port command)					
	Transfer time (ms)	0					

Index		Model		1kVA	1kVA(L)	2kVA	2kVA(L)	3kVA	3kVA(L)	
		Overload capacity	Low overload for 1min	1000VA/900W Load≤1300VA/1040W	<	2000VA/1800W Load≤2600VA/2080W	<	3000VA/2700W Load≤3900VA/3120W	<	
Medium overload for 1s	1300VA/1040W Load≤1500VA/1200W		<	2600VA/2080W Load≤3000VA/2400W	<	3900VA/3120W Load≤4500VA/3600W	<			
Heavy overload for 200ms	Load>1500VA/1200W			Load>3000VA/2400W		Load>4500VA/3600W				
Others	Backup time	With full load for 3min	Long backup time Can be configured any backup time according to needs	With full load for 3min	Long backup time Can be configured any backup time according to needs	With full load for 3min	Long backup time Can be configured any backup time according to needs			
	Charge recovery time	For standard model, the charge recovery time is less than 10 hours. For long backup model, the charge recovery time is determined by the capacity of external battery pack.								
	Communication interface	Equips RS232 port to support UPS power management software								
	Panel display	LCD shows the running status of the UPS								
	Alarm function	Alarm for battery low-voltage, mains abnormal, UPS fault, output overload.								
	Protection function	Protect for battery under-voltage, overload, short-circuit, over-temperature, input over-voltage								
	Noise (dB)	<50					<55			
	Work temperature (°C)	-5 ~ 40								

Index \ Model		1kVA	1kVA(L)	2kVA	2kVA(L)	3kVA	3kVA(L)
		Relative humidity	0 ~ 95%, non-condensation				
Size (W × D × H) (mm)	438×413×86						
UPS weight (kg)	11	5.8	7.2	8	7.2	8	
Battery box weight (kg)	--	13	13	17.5	17.5	24	

- Specifications are subject to change without prior notice.

A.2 6kVA(L)、10kVA (/B)

Index		Model		
		6kVA(L)	10kVA(/B)	
Input	Voltage range (V)	When the voltage within the range of 176Vac~275Vac, the UPS can bear 100% full load; When the voltage within the range of 80Vac~176Vac, the load carrying capacity linear decreases according to the input voltage amplitude.		
	Frequency range (Hz)	50/60±10%(50/60 self-adaption)		
	Input way	Sine-wave		
	Battery voltage (V)	192 (default) (can be set to 12~20 cells *12V by communication)		
Output	Capacity (VA/W)	6000/5400	10000/9000	
	Voltage (V)	220±2% (default) (can be set to 208/220/230/240)		
	Frequency (Hz)	50/60±0.2% (battery mode)		
	Wave form	Sine-wave		
	Voltage distortion	THD <1% (linear load); THD<4%(non-linear load)		
	Power factor	0.9 (at the room temperature, the power factor can be 1.0, and the UPS can carry load normally)		
	Transfer time (ms)	0		
	Overload capacity	Low overload for 10min	6900VA/6210W < Load≤7800VA/7020W	11500VA/10350W < Load≤13000VA/11700W
		Medium overload for 30s	7800VA/7020W < Load≤9000VA/8100W	13000VA/11700W < Load≤15000VA/13500W
		Heavy overload for 500ms	Load>9000VA/8100W	Load>15000VA/13500W
Mechanical part	Size (W×D×H) (mm)	438×500×86		
	Weight(kg)	10.6	12.2	

Index		Model	
		6kVA(L)	10kVA(/B)
Others	Backup time	For long backup model, it can be configured any backup time according to needs	For long backup model, it can be configured any backup time according to needs.
	Charge recovery time	It is determined by the capacity of external battery pack.	
	Communication interface	RS232 port	
	Panel display	LCD shows the running status of the UPS.	
	Alarm function	Alarm for battery low-voltage, mains abnormal, UPS fault, output overload.	
	Protection function	Protect for battery under-voltage, overload, short-circuit, over-temperature, input over-voltage	
	Noise (dB)	<55	
	Work temperature (°C)	-5 ~40	
	Relative humidity	0 ~ 95%, non-condensation	

- Specifications are subject to change without prior notice.

B Acronyms and Abbreviations

A

AC Alternating Current

D

DC Direct Current

E

ECO Energy Control Operation

EPO Emergency Power Off

L

LCD Liquid Crystal Display

R

RH

RS232 Recommend Standard232

S

SNMP Simple Network Management Protocol

U

UPS Uninterruptible Power System

